

Specifications of LVDT/HC-pilot burner

Typical burner data				
60° F – 21 % O ₂ combustion air – 50 % humidity – natural gas with 1000 Btu/ft ³ HHV - sg = 0.6 [1] Stated pressures are indicative - actual pressures are function of air humidity, altitude, type of fuel, gas quality				
Type		LVDT	HC	BSTD
Capacity	(MBtu/h)	68 (51-85)	68 (51-85)	290
Air (required air flow on scanner connection)	scfm	2 -2.3	2 -2.3	2 -2.3
Air pressure (relative to process back pressure)	[2] ("wc)	28	28	28
Natural gas pressure (relative to process back pressure)	[2][3] ("wc)	12	803 - 1605	803 - 1605
Propane pressure (relative to process back pressure)	("wc)	4.8	401 - 803	401 - 803
Flame length (outside the pilot burner)	[4] in.	3.9 - 6	3.9 - 6	7.8

[1] sg (specific gravity) = relative density to air (density air = 0.0763 lb/ft³(st)).

[2] Measured at pilot inlet.

[3] Customized orifices can be supplied for different gas pressures.

[4] Measured from outlet pilot tube (see page 4-22.4-3).



The LVDT/HC-pilot burner is designed for interrupted operation.

For special application and in specific conditions, an intermittent pilot version may be supplied on request. Contact MAXON for more details.

Materials of construction

Pilot tube	AISI304 (1.4301)
Spark ignitor holder	AISI304 (1.4301)
Spark ignitor	AISI304 (1.4301) + porcelain insulator
Ball valve	AISI304 (1.4301)

Selection criteria

Refer to the product data of AIRFLO® "LV", "HC", DELTA-TE™ and COMBUSTIFUME® burners.
Refer to page 4-22.4-3.

Standard available LVDT/HC-pilot burners (other combinations are possible on request)

Pilot type	Length X (inches)	MAXON compatible burners
LVDT-450	18	"LV" / COMBUSTIFUME® / DELTA-TE™
LVDT-600	23.6	"LV" / COMBUSTIFUME® / DELTA-TE™
LVDT-750	29.5	"LV" / COMBUSTIFUME® / DELTA-TE™
LVDT-900	35.4	"LV" / COMBUSTIFUME® / DELTA-TE™
LVDT-X	customized max.: 59	"LV" / COMBUSTIFUME® / DELTA-TE™
HC-X-SM	customized max.: 59	HC-S / HC-M / "LV" / COMBUSTIFUME® / DELTA-TE™
HC-X-L	customized max.: 59	HC-L
HC-US-X-SM	customized max.: 59	HC-S / HC-M / "LV" / COMBUSTIFUME® / DELTA-TE™
HC-US-X-L	customized max.: 59	HC-L
HC-EEx-X-SM	customized max.: 59	HC-S / HC-M / "LV" / COMBUSTIFUME® / DELTA-TE™
HC-EEx-X-L	customized max.: 59	HC-L
HC-BSTD-X	customized: 59 - 197	HC-S / HC-M / "LV" / COMBUSTIFUME® / DELTA-TE™
HC-BSTD-US-X	customized: 59 - 157.4	HC-S / HC-M / "LV" / COMBUSTIFUME® / DELTA-TE™



When ATEX category 2G (European hazardous area zones 1 & 2) applies, an –EEx type pilot burner shall be selected. Additional material needs to be ordered in this case:

- ignition coil
- spark pulse generator (SPG)
- EExd-box to house the SPG in case the SPG is mounted in an hazardous area itself

For use in very humid atmospheres (low temperature dryers) a special quartz insulated spark ignitor is optionally available. Refer to page 4-22.4-9.

Dimensions & weights

LVDT / HC - types (non EEX, non BSTD)

- 1) UV scanner connection 1"
- 2) Scanner cooling & combustion air inlet 1/2"
- 3) Alternative cooling & comb. air inlet 1/2"
- 4) Test connection combustion air 1/8"
- 5) Pilot gas inlet 1/4"
- 6) Spark ignitor
- 7) Pilot gas pressure test connection
- 8) Stainless steel pilot tube
- 9) Gasket
- 10) Ball joint (only on -L type)

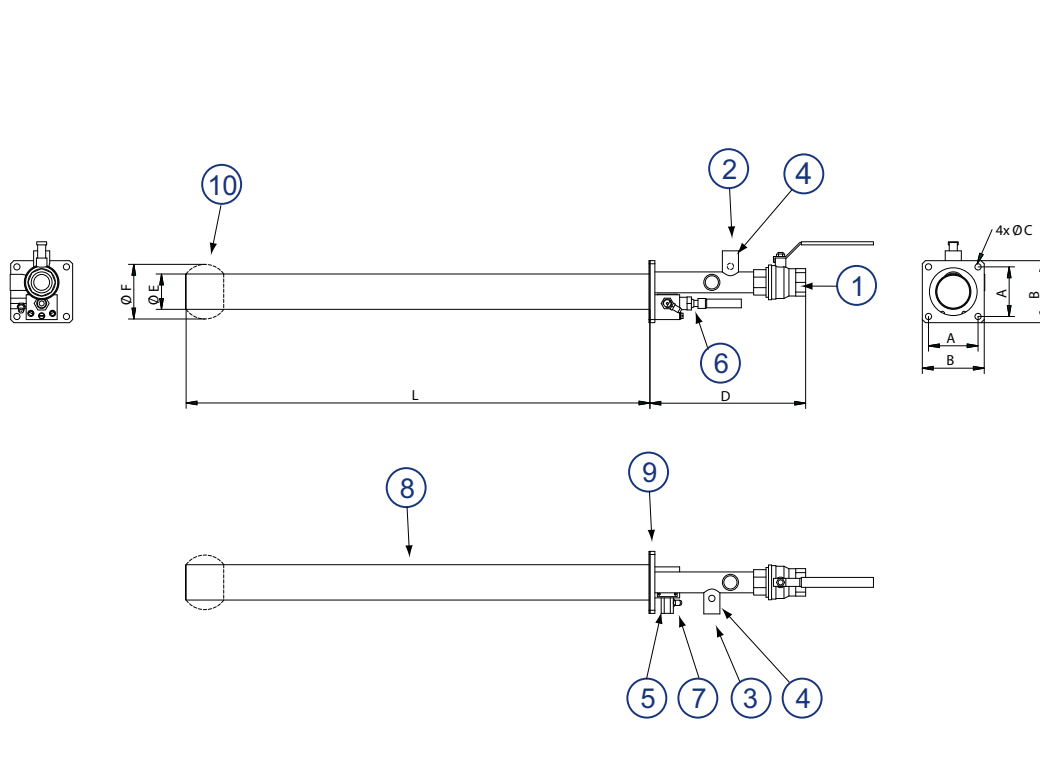

Dimensions in inches unless stated otherwise						
A	B	C Ø	D	E Ø	F Ø	Weight (lbs)
3	3.9	0.39	9.8	2.2	2.9	2 + (6 x L*)

* L = tube length in ft



Air, gas and test connections are ISO female threaded for European versions, NPT female threaded for US version pilots. Except UV scanner connection: this is ISO female threaded in both versions.

LVDT / HC-SM / HC-L - EEx -types

- 1) UV scanner connection 1"
- 2) Scanner cooling & combustion air inlet 1/2"
- 3) Pressure test connection 1/2"
- 4) Test connection combustion air 1/8"
- 5) Pilot gas inlet 1/4"
- 6) EEx spark ignitor
- 7) Pilot gas pressure test connection
- 8) Stainless steel pilot tube
- 9) Gasket
- 10) Ball joint
(only on HC-L type)

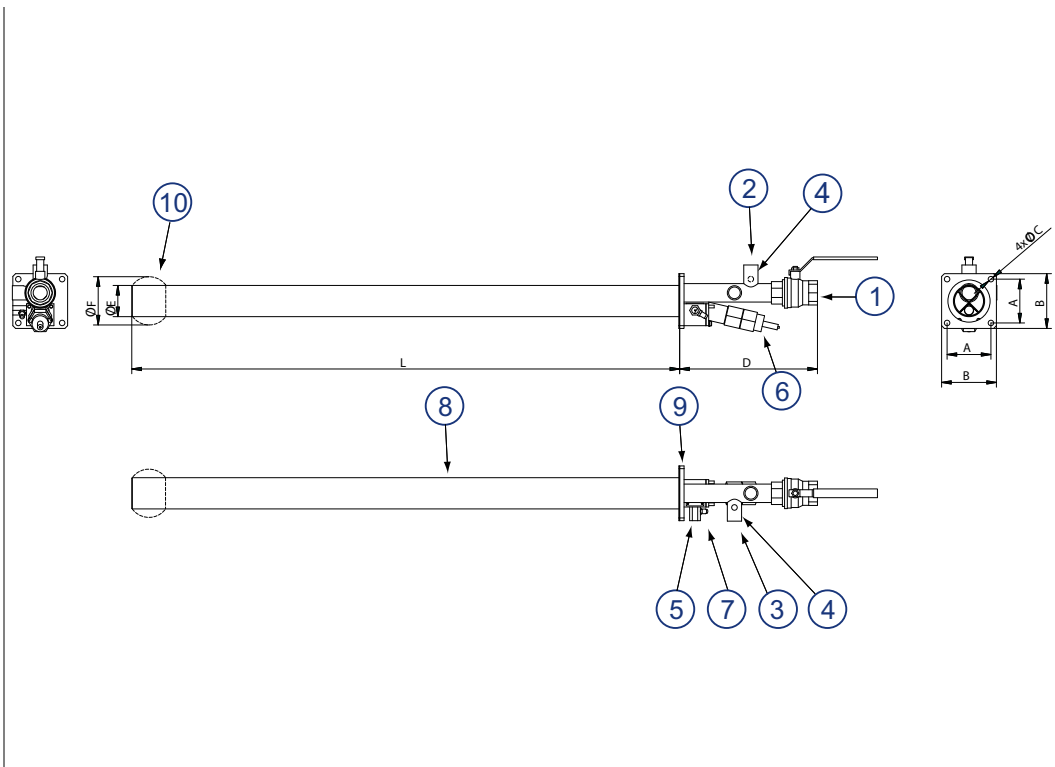

Dimensions in inches unless stated otherwise						
A	B	C Ø	D	E Ø	F Ø	Weight (lbs)
3	3.9	0.39	9.8	2.2	2.9	2 + (6 x L*)

* L = tube length in ft



Air, gas and test connections are ISO female threaded for European versions, NPT female threaded for US version pilots. Except UV scanner connection: this is ISO female threaded in both versions.

LVDT / HC-SM / HC-L - BSTD - types

- 1) UV scanner connection 1"
- 2) Scanner cooling & combustion air inlet 1/2"
- 3) Pressure test connection 1/2"
- 4) Test connection combustion air 1/8"
- 5) Pilot gas inlet 1/4"
- 6) EEx spark ignitor
- 7) Pilot gas pressure test connection
- 8) Stainless steel pilot tube
- 9) Gasket
- 10) Ball joint (only on HC -L type)

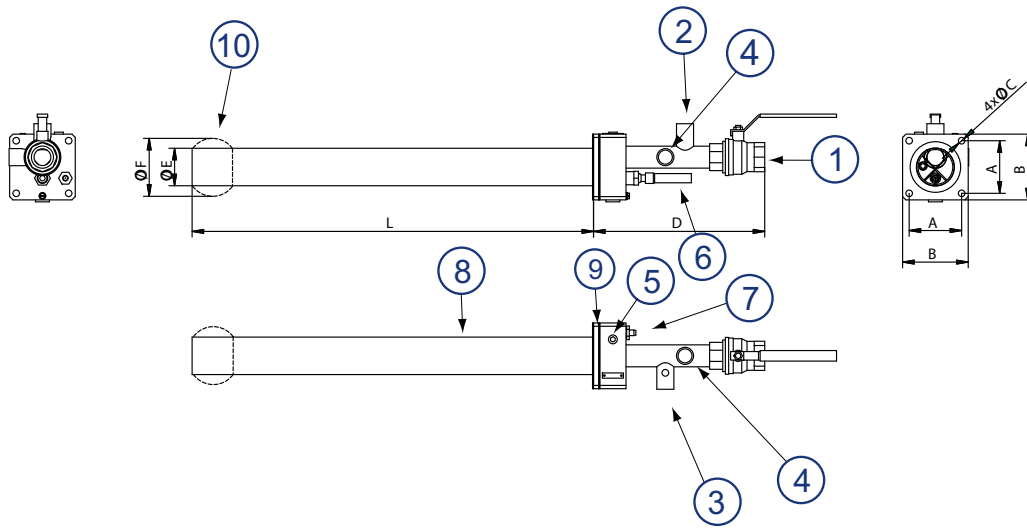

Dimensions in inches unless stated otherwise						
A	B	C Ø	D	E Ø	F Ø	Weight (lbs)
3	3.9	0.39	9.8	2.2	2.9	2 + (6 x L*)

* L = tube length in ft



Air, gas and test connections are ISO female threaded for European versions, NPT female threaded for US version pilots. Except UV scanner connection: this is ISO female threaded in both versions.

Spark ignitors

Spark ignitors are available in different lengths and can be ordered separately. MAXON advises to keep spark ignitors as spare parts. The spark ignitors are supplied including the spark ignitor holder, which facilitates on site replacement.

Available spark ignitor types		
Type	Length A (inches)	Remark
SI-LVDT-450	15.7	standard length
SI-LVDT-600	21.6	
SI-LVDT-750	27.5	
SI-LVDT-900	33.4	
SI-LVDT-X	L-50 [1]	customized length
SI-HC-EEEx-X	L-50 [1]	spark ignitor for EEx pilot burners
SI-HC-BSTD-X	L-50 [1]	spark ignitor for boosted pilot burners
SI-LVDT-QRTZ	L-50 [1]	one piece quartz insulator for use in very humid atmospheres

[1] L = pilot burner tube length

To define the spark ignitor, the correct type should be known. In addition, the length "A" should be specified when ordering. This length can be determined by measuring the length of the spark ignitor from the tip to the holder or it can be found engraved in the spark ignitor holder.

1) "A" length

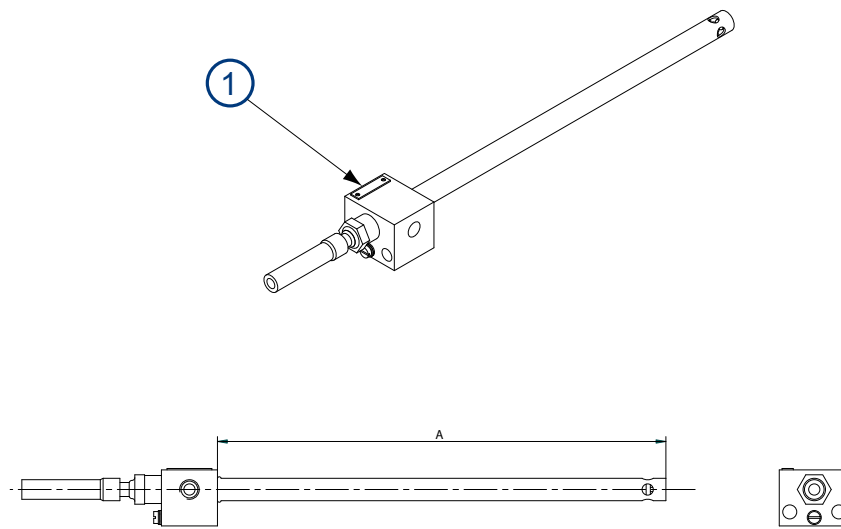

Spark ignitor with holder

Installation and operating instructions

Application requirements

View port

A view port to inspect burner flame is essential to inspect flame aspect. It is recommended to install the view port downstream the burner on the opposite side of the process air duct.

Required ancillary equipment

Ensure that all required ancillary equipment for safe operation and correct performance of the LVDT/HC-pilot burner is installed, as described in the applicable local codes and/or process-related instructions. Proper adjustment of air- and gas pressures is essential for optimal operation of the burner.

Positioning of the LVDT/HC-pilotburner.

The LVDT/HC-burner is designed to be used on AIRFLO® "HC", "LV", COMBUSTIFUME® and DELTA-TE™ burners. They shall only be mounted on these burners on the special mounting plates foreseen. Refer to literature on above mentioned MAXON burners.

Installation

Storage

LVDT/HC-pilot burners should be stored dry (inside). Prevent that water and/or dust can penetrate into the burner parts during storage.

Handling

Handle burner with care during unpacking, transport, lifting and installation. Use proper equipment. Any impact on the burner could result in damage.



Pay special attention when handling QRTZ type spark ignitors since these are very fragile.

Flange the pilot burner to the installation

Each pilot burner is equipped with a mounting plate that fits the mounting plate of the main burner. Bolt this mounting plate to the main burner. Use proper gasket, included with the pilot burner. Tighten the four flange bolts with the correct torque. Retighten all bolts after first firing and regularly after commissioning. Refer to main burner specification sheets for correct mounting position.

Orientation



The orientation of the pilot burner on the main burner shall always ensure that the spark ignitor is mounted "upstream" (= closest to the burner body) of the UV scanner. Pilots should be mounted horizontally or vertically facing down. Vertical mounted pilot burners are possible but special attention is required to avoid accumulation of foreign material in the scanner tube.

Start-up instructions

Instructions provided by the company or individual responsible for the manufacture and/or overall installation of a complete system incorporating MAXON burners take precedence over the installation and operating instructions provided by MAXON. If any of the instructions provided by MAXON are in conflict with local codes or regulations, please contact MAXON before initial start-up of equipment.



Read the combustion system manual carefully before initiating the start-up and adjustment procedure. Verify that all of the equipment associated with and necessary to the safe operation of the burner system has been installed correctly, that all pre-commissioning checks have been carried out successfully and that all safety related aspects of the installation are properly addressed.

Initial adjustment and light-off should be undertaken only by a trained commissioning engineer.

Safety interlocks

Guarantee that all the required safety locks as described in the applicable local codes or regulations, or supplementary safety interlocks required for safe operation of the overall installation, are working properly and resulting in a positive safety-lock of the burner. Do not bypass any of these safety interlocks, this will result in unsafe operation.

Checks during and after start-up

During and after start-up, check the integrity of the system. Check all bolted connections after first firing (first time on temperature) and retighten if necessary.

Purge

For safety-reasons, it is required to purge the installation sufficiently long to ensure that all possible combustibles are evacuated before ignition. Refer to the applicable local codes and your specific application requirements to determine the purge time.

Pilot ignition

Pilot burner does not require adjusting thanks to its fixed gas and air orifices. Refer to table page 4-22.4-4 for correct differential pressures.

Maintenance and inspection

Safety requirements

Regular inspection, testing and recalibration of combustion equipment according to the installation's manual is an integral part of its safety. Inspections activities and frequencies shall be carried out as specified in the installation's manual.

Perform the following activities at least annually as part of a recommended preventative maintenance routing:

- Inspect burner internal parts for wear and oxidation, paying special attention to the spark ignitor tip
- Inspect associated control instruments and devices for function with particular attention to all safety permissive switches

Visual inspections

Regular visual inspection of all connections (air and gas piping to the burner, bolting of the burner mounting flange, burner support in the duct) and burner flame shape and aspect are essential for safe operation.

Recommended spare parts

Keep local stock of spark ignitor and holder. It is not recommended to keep local stock of other pilot burner parts.