

Eclipse Primefire Forehearth Burners

Version 1

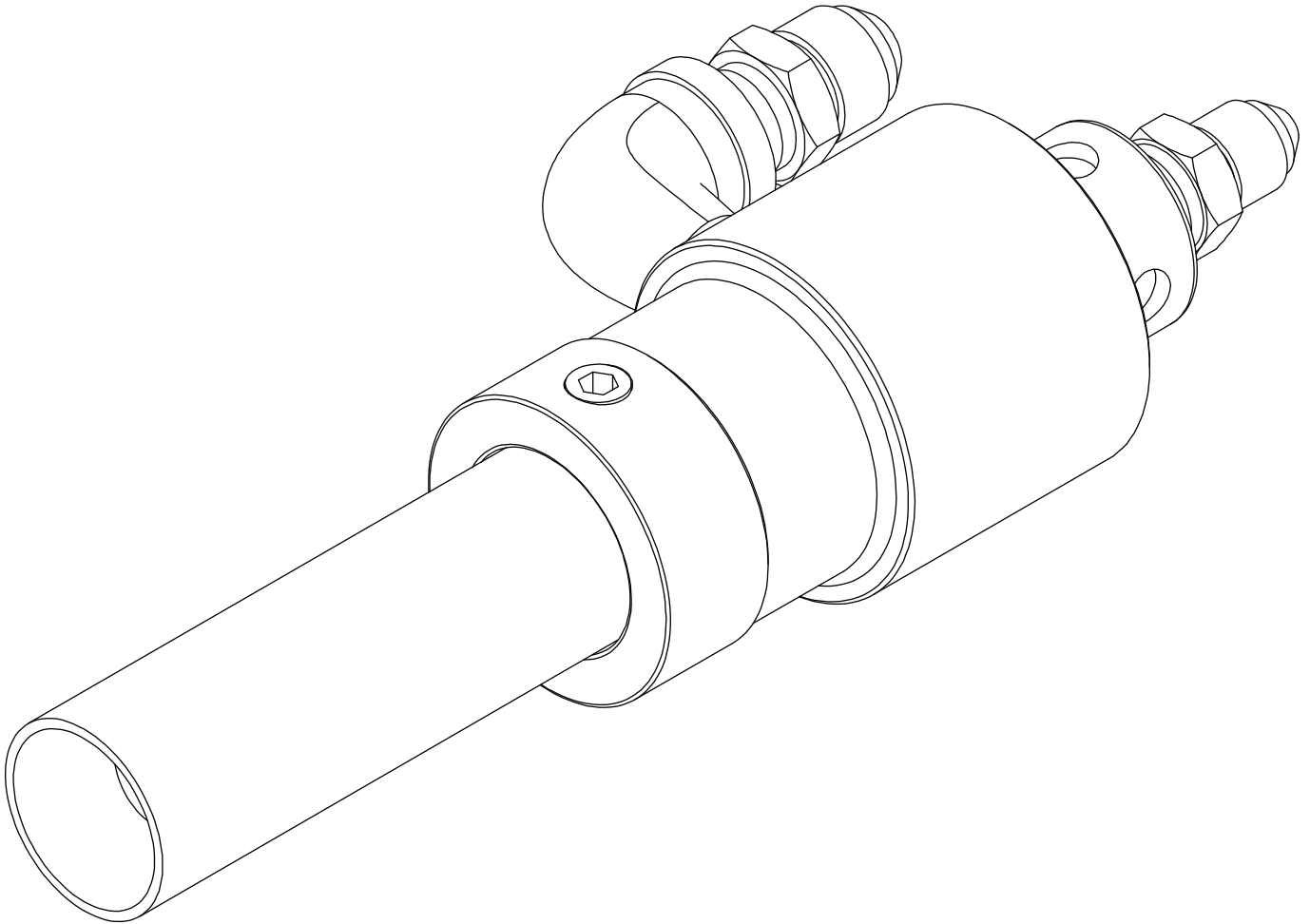

Copyright

Copyright 2013 by Eclipse, inc. All rights reserved worldwide. This publication is protected by federal regulation and shall not be copied, distributed, transmitted, transcribed or translated into any human or computer language, in any form or by any means, to any third parties, without the express written consent of Eclipse, inc.

Disclaimer Notice

In accordance with the manufacturer's policy of continual product improvement, the product presented in this brochure is subject to change without notice or obligation.

The material in this manual is believed adequate for the intended use of the product. If the product is used for purposes other than those specified herein, confirmation of validity and suitability must be obtained. Eclipse warrants that the product itself does not infringe upon any United States patents. No further warranty is expressed or implied.

Liability & Warranty

We have made every effort to make this manual as accurate and complete as possible. Should you find errors or omissions, please bring them to our attention so that we may correct them. In this way we hope to improve our product documentation for the benefit of our customers. Please send your corrections and comments to our Technical Documentation Specialist.

It must be understood that Eclipse's liability for its product, whether due to breach of warranty, negligence, strict liability, or otherwise is limited to the furnishing of replacement parts and Eclipse will not be liable for any other injury, loss, damage or expenses, whether direct or consequential, including but not limited to loss of use,

income, or damage to material arising in connection with the sale, installation, use of, inability to use, or the repair or replacement of Eclipse's products.

Any operation expressly prohibited in this manual, any adjustment, or assembly procedures not recommended or authorized in these instructions shall void the warranty.

Document Conventions

There are several special symbols in this document. You must know their meaning and importance.

The explanation of these symbols follows below. Please read it thoroughly.

How To Get Help

If you need help, contact your local Eclipse representative. You can also contact Eclipse at:

1665 Elmwood Rd.
Rockford, Illinois 61103 U.S.A.
Phone: 815-877-3031
Fax: 815-877-3336
<http://www.eclipsenet.com>

Please have the information on the product label available when contacting the factory so we may better serve you.

 ECLIPSE <small>Innovative Thermal Solutions</small>	www.eclipsenet.com
Product Name	
Item #	
S/N	
DD MMM YYYY	



This is the safety alert symbol. It is used to alert you to potential personal injunt hazards. Obey all safety messages that follow this symbol to avoid possible injury or death.



Indicates a hazardous situation which, if not avoided, will result in death or serious injury.



Indicates a hazardous situation which, if not avoided, could result in death or serious injury.



Indicates a hazardous situation which, if not avoided, could result in minor or moderate injury.

NOTICE

Is used to address practices not related to personal injury.

NOTE

Indicates an important part of text. Read thoroughly.



Table of Contents

Introduction	4
Product Description	4
Audience	4
WTPUG Documents	4
Purpose	4
Safety	5
Capabilities	5
Operator Training	5
Replacement Parts	5
Installation	6
Handling & Storage	6
Approval of Components	6
WTPUG Water-Cooled Throughport Gas Burner	7
Burner Cooling Water System	7
Typical Closed-Loop Water System Description	7
Retractable Burner Systems for Eclipse-Supplied Retraction Mechanism	7
Retraction Gear Installation	8
Burner Installation and Operation	9
Maintenance	10
Periodic Checklist	10
Monthly Checklist	10
Yearly Checklist	10
Instructions for Cleaning	10
Removal of the Pneumatic Cylinder for Eclipse-Supplied Retraction Mechanisms	10
Appendix	i
Notes	iv

Introduction

1

Product Description

Forehearth air and oxygen gas burners are small, nozzle mixing burners designed to be inserted into the forehearth to provide temperature homogeneity throughout the glass by increasing the heat of the glass melt in the area near the forehearth wall where cooling occurs more rapidly.

These burners consist of a 300-series stainless steel gas tip and either a 300-series stainless steel or Inconel air nozzle. They produce a short, bright flame intended to keep the temperature of the glass near the forehearth wall, where cooling is most rapid, at the same level as the middle of the glass bed.

Forehearth burners use one size body for all nozzle sizes making for easier maintenance and greater capacity flexibility. They can fire natural gas, propane, butane or mixed fuels. Block design must be compatible with nozzle dimensions.

Audience

This manual has been written for people who are already familiar with all aspects of a glass burner and its add-on components, also referred to as “the burner system”.

These aspects are:

- Installation
- Use
- Maintenance

The audience is expected to have previous experience with this type of equipment.

Benefits

- 80% reduction in NO_x emissions.
- 60% reduction in fuel consumption using oxy/gas.
- Improved temperature homogeneity throughout the glass.
- Reduced maintenance.
- Reduced safety issues.
- Ease of set-up and operation.
- No blowers required for the combustion process

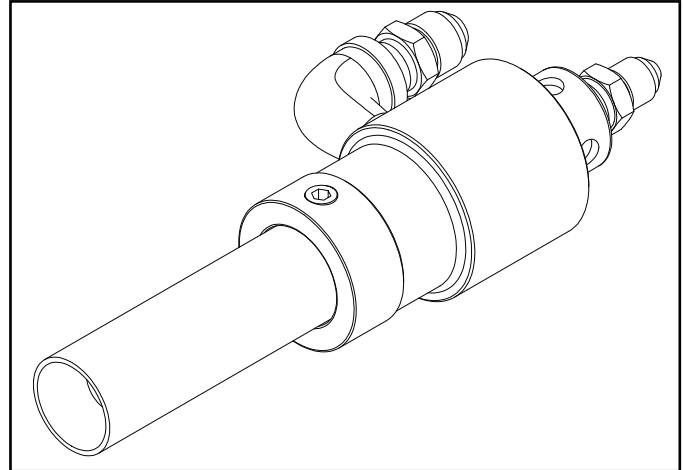

Figure 1.1. Forehearth Burner

Forehearth Documents

Information Guide 1125

- This document

Datasheet 1125-1 through 1125-4

- Required to complete design and selection

Spare Parts List 1141-4

- Recommended replacement part information

Related Documents

- EFE 825 (Combustion Engineering Guide)
- Eclipse Bulletins and Info Guides: 710, 732, 760, 818, 830, 832, 852, 854, 856, 610, 820, 902, 930

Purpose

The purpose of this manual is to ensure the installation and adjustment of a safe, effective and trouble-free combustion system.

Safety

2

Important notices, which help provide safe burner operation, will be found in this section. To avoid personal injury and damage to the property or facility, the following warnings must be observed. All involved personnel should read this entire manual carefully before attempting to start or operate this system. If any part of the information in this manual is not understood, contact Eclipse before continuing.



WARNING

- **DO NOT disassemble any component WITHOUT first reading the manufacturer's instructions. Several components contain parts under compression or pressure and could injure personnel if not disassembled properly.**
- **Control panels contain voltages which can severely injure personnel. These panels are normally double fed from the emergency supply. NO engineer/maintenance technician who is not fully conversant with the equipment should be allowed access to the panel internals.**
- **Control circuits MUST not be altered at any time unless Eclipse has been consulted and has approved the modifications.**
- **No naked lights are to be used in the area of gas pipeline components.**
- **Any gas leaks should always be isolated and rectified immediately. Any piece of pipeline equipment and its surrounding area should be properly vented and/or purged as appropriate after isolation and before the start of any maintenance.**
- **Extreme care should be taken when working on burner equipment installed under the furnace port.**
- **Eclipse recommends installing a safety guard around moving parts.**
- **Eclipse recommends considering any area with moving mechanical parts a restricted area.**
- **The burners, described herein, are designed to mix fuel with air and burn the resulting mixture. All fuel burning devices are capable of producing fires and**

explosions if improperly applied, installed, adjusted, controlled or maintained.

- **Do not bypass any safety feature; fire or explosion could result.**
- **Never try to light a burner if it shows signs of damage or malfunction.**
- **The burner and duct sections are likely to have HOT surfaces. Always wear the appropriate protective equipment when approaching the burner.**

NOTICE

- **This manual provides information regarding the use of these burners for their specific design purpose. Do not deviate from any instructions or application limits described herein without written approval from Eclipse.**

Capabilities

Only qualified personnel, with sufficient mechanical aptitude and experience with combustion equipment, should adjust, maintain or troubleshoot any mechanical or electrical part of this system.

Operator Training

The best safety precaution is an alert and trained operator. Train new operators thoroughly and have them demonstrate an adequate understanding of the equipment and its operation. A regular retraining schedule should be administered to ensure operators maintain a high degree of proficiency.

Replacement Parts

Order replacement parts from Eclipse only. All Eclipse approved valves or switches should carry UL, FM, CSA, CGA and/or CE approval where applicable.

Installation

In this section you will find information and instructions needed to install the burner and the system components.

Handling & Storage

Handling

- Make sure the area is clean.
- Protect all components from weather, damage, dirt and moisture.
- Protect the components from excessive temperatures and humidity.
- Take care not to drop or damage components.

Storage

- Make sure the components are clean and free of damage.
- Store the components in a cool, clean, dry room.
- After you have made sure everything is present and in good condition, keep the components in their original packaging as long as possible

Approval of Components

Limit Controls & Safety Equipment

All limit controls and safety equipment must comply with all applicable local codes and/or standards and must be listed for combustion safety by an independent testing agency. Typical application examples include:

- American: NFPA 86 with listing marks from UL, FM, CSA
- European: EN 746-2 with CE mark from TuV, Gastec, Advantica

Electrical Wiring

All the electrical wiring must comply with all applicable local codes and/or standards such as:

- NFPA Standard 70
- IEC60364
- CSA C22
- BS7671

Gas Piping

All the gas piping must comply with all applicable local codes and/or standards such as:

- NFPA Standard 54
- ANSI Z223
- EN 746-2

Where to Get the Standards:

The NFPA Standards are available from:
National Fire Protection Agency
Batterymarch Park
Quincy, MA 02269
www.nfpa.org

The ANSI Standards are available from:
American National Standard Institute
1430 Broadway
New York, NY 10018
www.ansi.org

The UL Standards are available from:
333 Pfingsten Road
Northbrook, IL 60062
www.ul.com

The FM Standards are available from:
1151 Boston-Providence Turnpike
PO Box 9102
Norwood, MA 02062
www.fmglobal.com/approvals

Information on the EN standards and where to get them is available from:
Comité Européen de Normalisation
Stassartstraat 36
B-1050 Brussels
Phone: +32-25196811
Fax: +32-25196819
www.cen.eu

Comité Européen de Normalisation Electronique
Stassartstraat 36
B-1050 Brussels
Phone: +32-25196871
Fax: +32-25196919
www.cenelec.org

Forehearth Oxy/Gas and Air/Gas Burners

The oxy/gas forehearth burners consist of a stainless steel body that is universal for all oxygen and gas nozzle sizes. Gas tips are made of 304 or better stainless steel while oxygen nozzles are available in 304 or better stainless steel or Inconel 601 to provide additional resistance to oxidation at higher temperatures. Air/gas nozzles are made of 304 or better stainless steel.

Burners are available in lengths (measured from the tip of the oxygen nozzle to the fittings) of 10 inches to 20 inches. Custom piping length is also available to fit specific installations.

Forehearth burners are mounted directly into the forehearth burner blocks with no special mounting equipment required.

Burner Installation and Operation

Initial Forehearth Start-Up

NOTE: Burners should be out of the forehearth during heatup.

1. Connect the oxygen (or air) and gas supply lines to fittings on the burner.
2. Make sure all systems are checked and ready.
3. Make sure all burner isolation valves are closed.
4. Open oxygen and gas to the zone controls.
5. Allow oxygen and gas to flow through the burner to ensure gas and oxygen lines are purged.
6. Allow chamber to reach a minimum temperature of 1500 °F (816 °C) to ensure the auto-ignition point of natural gas has been reached before inserting burners and opening oxygen and gas valves.

NOTE: For oxygen burner starts, it is best to allow the furnace to rise to a temperature between 1652 °F (900 °C) to 1832 °F (1000 °C), if possible.

7. Install about half of the burners in a zone.

NOTE: It is suggested that this initially be in an area away from the heat-up burner.

8. Open the oxygen valve for the burners installed in step 7.

9. With oxygen flowing, set the oxygen flow per burner to the flow in the following table based on burner model:

Oxygen Flow chart

Model	Oxygen Flow, scfh (Nm3/hr)
FH012	10 (0.28)
FH017	14 (0.40)
FH025	30 (0.85)
FH050	40 (1.13)

10. Open the natural gas valve.

11. Start the natural gas flow and bring up to a flow per burner from the following table based on the burner model:

Gas Flow Chart

Model	Gas Flow, scfh (Nm3/hr)
FH012	5 (0.14)
FH017	7 (0.20)
FH025	15 (0.42)
FH050	20 (0.57)

12. Check burners to verify ignition and listen for a “screaming” or “squealing” sound. If the burners are making these sounds, open or close the gas to the burner until the sound goes away. If the sound persists, shut off gas flow to the zone and check burners for damage as well as to verify gas and oxygen/air connections are not reversed.

NOTE: During the initial light off/heat-up, it is better to run the flame slightly gas rich.

13. Ensure heat-up burner flame is not pushing forehearth burner flame into the side of the block bore.

14. Add or reduce gas and oxy/air to keep the furnace temperature on the heat up curve.

NOTE: Burners should always be operated above minimum flow and below maximum flow.

15. Heat-up burner turndown and removal

- It is recommended to start with burners away from the heat-up burner first.
- As forehearth burners are turned on, lower the gas flow to the heat-up burner.
- When the flow to the heat-up burner is low enough, shut off the gas flow and remove the burner.

NOTE: Pay attention to the forehearth pressure during this procedure and close off the stack as needed.

NOTE:With oxy firing, the pressure will drop off significantly. Add fuel/oxygen to hold temperature, then add burners as necessary.

16. Repeat steps 3-15 for each zone.
17. Remove a burner and check the appearance of the flame.
18. Add burners as needed but ensure the flow of oxygen and gas remain below the maximum and above the minimum flow rates for each burner.

Installing Burners in Hot Furnace (minimum temperature of 1500° F (816° C))

1. Connect gas and oxy (or air) supply lines to burner fittings.
2. Make sure all systems are checked and ready.
3. Make sure burner isolation valves are closed.
4. Open oxygen or air valve to the burner.
5. Slowly open the gas valve to the burner to ignite the flame.
6. Open gas valve to the burner to set flow to desired rate.

Preventative maintenance is the key to a reliable, safe and efficient system. The following are suggested guidelines for periodic maintenance. Burners in severe environments or operational conditions should be checked more frequently. Spare burners not in use should be completely drained and stored vertically to prevent rusting.

NOTE: The periodic, monthly, and yearly lists are an average interval. If your environment is dirty, the intervals may be shorter. Check with local authorities having jurisdiction regarding their recommended maintenance schedules.

Periodic Checklist

1. Continuously monitor gas and oxygen (or air) flows.
2. Check flame shape to ensure there is nothing blocking the gas or oxygen/air nozzles which could cause damage to the burner and the burner block.
3. Remove burners and inspect tips for signs of carbon build-up as well as checking for any damage to the burner blocks that could result from dirty nozzles/ incorrect flows, or loose oxygen/air nozzles at least four times per year.

Monthly Checklist

1. Clean all burner oxygen (or air) nozzles on a routine basis once per month and when required by flame appearance.
2. Check for proper air/gas or oxygen/gas pressures (refer to Forehearth Datasheets 1125-1, -2, -3, or -4.)
3. Test all the system alarms for proper response signals.
4. Test the manual gas shut-off valves for proper operation.

Yearly Checklist

1. Test (leak test) safety shut-off valves for tightness of closure.
2. Test pressure switch settings by checking switch movements against pressure settings and comparing these with the actual impulse pressure.
3. Inspect impulse piping for leaks.
4. Clean and inspect all burners.

Instructions for Cleaning

1. Shut off the gas flow to the burner you are cleaning.
2. Allow the oxygen to flow for a few minutes to cool down the oxygen nozzle.
3. Shut off the oxygen flow.
4. Remove the burner from the block.
5. Remove the oxygen nozzle and the gas tip from the burner body, using pliers if necessary.
6. Clean nozzles with a soft wire brush to remove any carbon build-up.
7. Reinstall on the burner body starting with the gas tip. Follow the installation procedures in this manual to reinstall the burner.

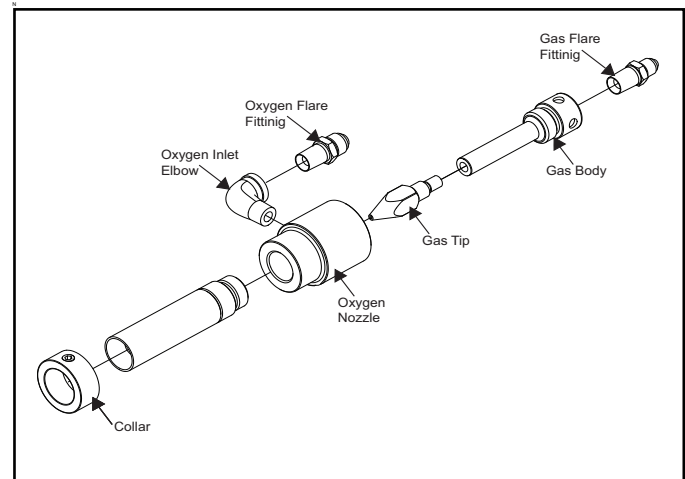

Figure 3.1. Forehearth Burner description



Appendix

Conversion Factors

Metric to English

From	To	Multiply By
actual cubic meter/h (am ³ /h)	actual cubic foot/h (acfh)	35.31
normal cubic meter/h (Nm ³ /h)	standard cubic foot /h (scfh)	38.04
degrees Celsius (°C)	degrees Fahrenheit (°F)	(°C x 9/5) + 32
kilogram (kg)	pound (lb)	2.205
kilowatt (kW)	Btu/h	3415
meter (m)	foot (ft)	3.281
millibar (mbar)	inches water column ("w.c.)	0.402
millibar (mbar)	pounds/sq in (psi)	14.5 x 10 ⁻³
millimeter (mm)	inch (in)	3.94 x 10 ⁻²
MJ/Nm ³	Btu/ft ³ (standard)	26.86

Metric to Metric

From	To	Multiply By
kiloPascals (kPa)	millibar (mbar)	10
meter (m)	millimeter (mm)	1000
millibar (mbar)	kiloPascals (kPa)	0.1
millimeter (mm)	meter (m)	0.001

English to Metric

From	To	Multiply By
actual cubic foot/h (acfh)	actual cubic meter/h (am ³ /h)	2.832 x 10 ⁻²
standard cubic foot /h (scfh)	normal cubic meter/h (Nm ³ /h)	2.629 x 10 ⁻²
degrees Fahrenheit (°F)	degrees Celsius (°C)	(°F - 32) x 5/9
pound (lb)	kilogram (kg)	0.454
Btu/h	kilowatt (kW)	0.293 x 10 ⁻³
foot (ft)	meter (m)	0.3048
inches water column ("w.c.)	millibar (mbar)	2.489
pounds/sq in (psi)	millibar (mbar)	68.95
inch (in)	millimeter (mm)	25.4
Btu/ft ³ (standard)	MJ/Nm ³	37.2 x 10 ⁻³

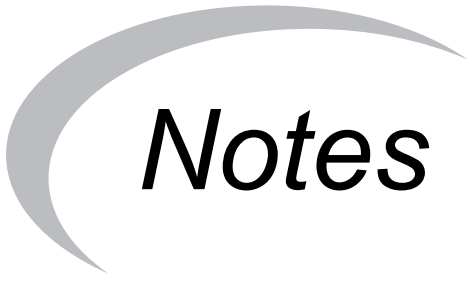

Notes

