

Series LV AIRFLO®

In-duct firing line burner



- Series LV AIRFLO® burners provide stable, efficient, raw gas operations in air streams with relatively low duct velocities. Duct static pressure drops may be as low as 0.2" wc.
- Produces clean and odor-free combustion with natural or propane gases.
- Air stream temperatures upstream of a Series LV AIRFLO® burner can be up to 1050°F.
- Low air stream oxygen levels can be tolerated without a need to add primary combustion air to the system.
- Modular burner design provides burner assembly configurations and total heat release for maximum application flexibility.
- 17 varieties of Series LV AIRFLO® burners available, each optimized in materials and/or performance factors to match your specific application requirements.

Product description

Series LV AIRFLO® principle

- 1) Fresh air
- 2) Gas
- 3) Hot air

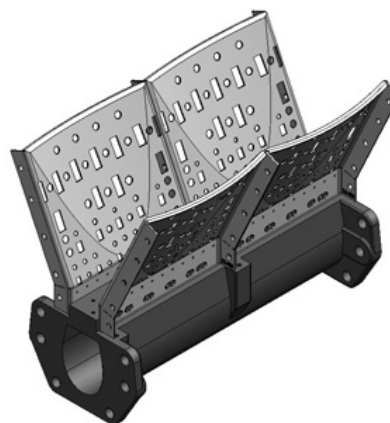
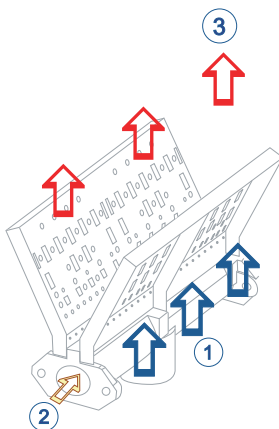

MAXON Series LV AIRFLO® burners are designed for heating process air in motion. An iron or aluminum bronze body which serves as the gas manifold is drilled to discharge the fuel gas between diverging mixing plates.

The entire burner assembly is mounted inside a process air duct directly in the air stream being heated. The air stream passes across the burner and through the mixing plates and is used as combustion air. Carefully controlled mixing plate aeration patterns give progressive mixing, superior cross-ignition and flame retention across the entire burner assembly length. The Series LV AIRFLO® burner burns clean and odor-free with low levels of NO_x production.

Correctly sized process air ducts and the resulting duct static pressure drop across the burner are the keys to successful operation.

Normal capacities vary widely with the application and the duct pressures. The fuel used and the design velocities will affect the burner turndown. Modular design permits the burner shape and total heat release to match the application needs.

Performance data varies depending upon temperature of air upstream and downstream of the burner assembly, the percentage of oxygen (by volume) in the passing air stream, and the allowable duct static pressure drop across the Series LV AIRFLO® burner.

Available product sizes

Several varieties of Series LV AIRFLO® burners are offered. Each type is optimized for a specific type of application. All varieties can be used as raw gas type systems or partial air/gas premixture for applications where higher upstream temperatures and/or lower oxygen levels are involved.

LV-NP1 AIRFLO® burner with its gray iron body and #321 stainless steel mixing plates is the most economical choice for a raw gas burner system for fresh air heating with low heat release per lineal foot and outlet temperatures up to 1000°F. For upstream process air temperature up to 600°F.

LV-3G AIRFLO® burners have gray iron bodies and #321 stainless steel mixing plates. Four different versions are available, either for raw gas burner applications or those requiring a partial air/gas premixture system and/or outlet temperatures up to 1000°F. For upstream process air temperature up to 600°F.

LV-4D AIRFLO® burners have a ductile iron body and #310 stainless steel mixing plates for applications with outlet temperatures up to 1500°F. For upstream process air temperature up to 1000°F.

LV-5D AIRFLO® burners complement their ductile iron bodies with Hastelloy-X mixing plates for use in applications with up to 1700°F outlet temperature requirements. For upstream process air temperature up to 1000°F.

LV-5B AIRFLO® burners have an aluminum bronze body casting with Hastelloy-X mixing plates for use with applications requiring up to 1700°F outlet temperatures. For upstream process air temperature up to 1050°F.

Typical burner data						
Fuel: natural gas at 60°F with 1000 Btu/ft ³ (st) HHV - sg = 0.6 [1]						
Combustion air: 60°F - 21% O ₂ - 50% humidity - sg = 1.0 [1]						
Stated pressures are indicative. Actual pressures are a function of air humidity, altitude, type of fuel and gas quality.						
Burner size		LV-NP1	LV-3G	LV-4D	LV-5D	LV-5B
Maximum capacity per foot [2]	MBtu/h	0.6	2.5	2.5	2.5	2.5
Minimum capacity per foot [2]	MBtu/h	0.03	0.075	0.075	0.075	0.075
Natural gas differential pressure [3]	"wc	4	28	28	28	28
Flame length [4]	inches	10	84	84	84	84
Pressure drop process air [5]	"wc	0.2 - 2.5				

[1] sg (specific gravity) = relative density to air (density air = 0.0763 lb/ft³ (st))

[2] Maximum and minimum capacities are highly dependent upon the application. Check "Specifications of LV AIRFLO burners" for more information.

[3] Natural gas differential pressure at burner inlet at maximum stated burner capacity. The stated values are valid for burners with standard gas drillings. Refer to "Specifications of LV AIRFLO burners" for gas differential pressures to be used with alternative gas drillings.

[4] Flame length at highest capacity and highest process air pressure drop across the burner when firing on fresh air. The flame length and flame aspect are highly dependent upon factors such as process air velocity and process air oxygen content. Refer to "Specifications of LV AIRFLO burners" for more information.

[5] Stated process air pressure drop across the burner should never exceed the specified range in this table. In some specific applications, the process air pressure drop range could be even more narrow.

Applications

Series LV AIRFLO® burners are designed for stable, efficient, raw gas operations in air streams with relatively low duct velocities. Duct static pressure drops may be as low as 0.2" wc or up to 2.5" wc.

Elevated air stream temperatures approaching the Series LV AIRFLO® burner can be as high as 1050°F . Reduced oxygen levels as low as 12% (by volume) are tolerated without a need to add primary combustion air. For applications with low oxygen levels, a partial premixture must be added through the system.

Typical applications include thermal incinerators, cogeneration, spray dryers, hot air generators with variable flows, rotating drum dryers and calciners.

- 1) LV AIRFLO® burner
- 2) Combustion chamber
- 3) Gas pipe train
- 4) MAXON shut-off valves

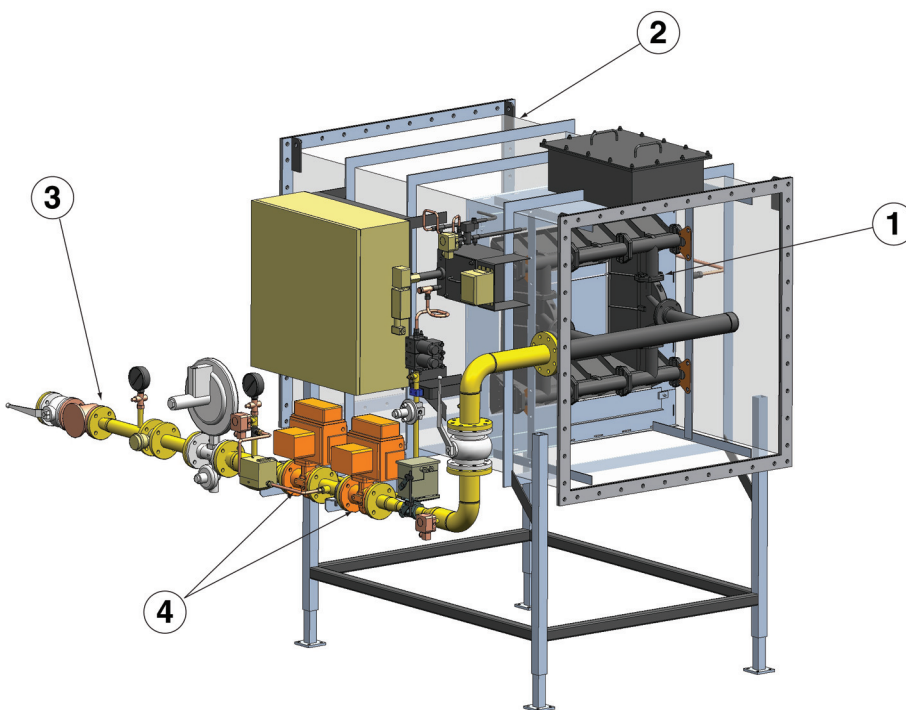

11.9 MBtu/h hot air generator with 9 ft LV-4D AIRFLO® burner to be used for the production of titanium dioxide

Dimensions and weights

LV-NP1 AIRFLO® burners

- 1) LV-NP1 AIRFLO® burner
- 2) LV-NP1 12 inch straight section
- 3) Typical end view for LV-NP1 burner sections

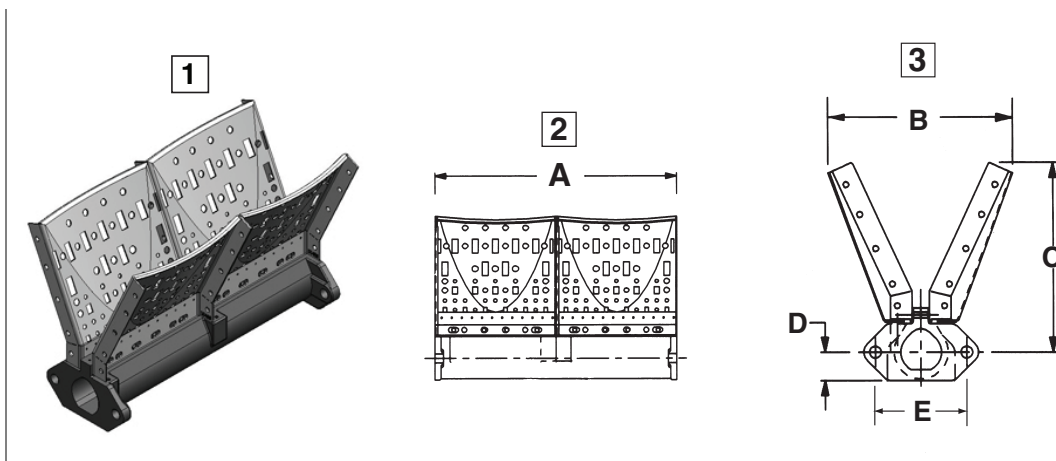

LV-3, -4, -5 AIRFLO® burners

- 1) LV-3, -4 & -5 AIRFLO® burner
- 2) LV-3 12 inch straight section
- 3) Typical end view for LV-3, -4 & -5 burner sections

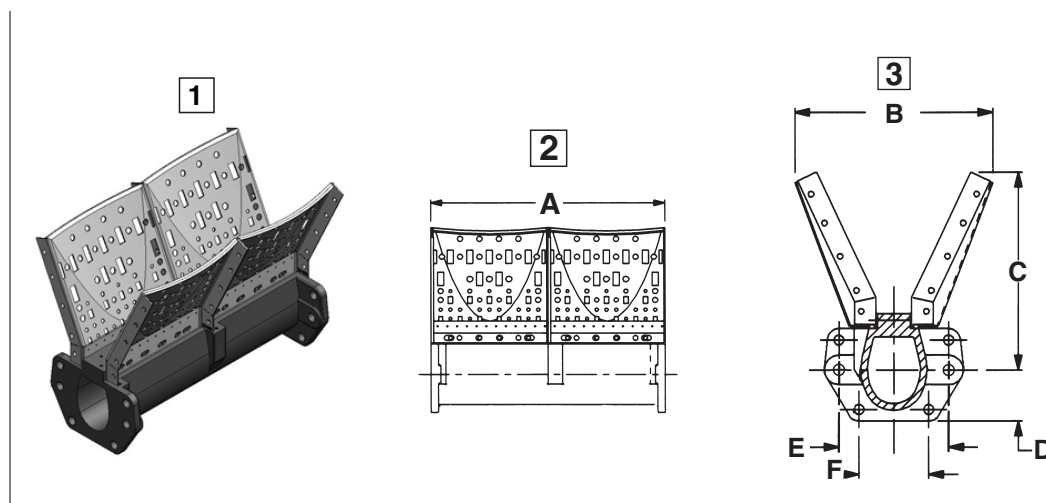

Dimensions in inches unless stated otherwise							
Burner size	A	B	C	D	E	F	Weight lbs
LV-NP1 12" straight section	12	6.84	7.0	1.06	3.38	---	13
LV-3, -4 & -5 12" straight section	12	7.44	7.5	1.94	4.12	2.62	21

Typical emissions

MAXON Series LV AIRFLO® burners are especially designed to meet the high demands of most of the local standards on air quality of direct fired process air heating applications worldwide.

If correctly used within the performance limits as described on page 4-21.4-7, both CO and NOx will remain far below the limits as determined in most standards.

Exact emissions performance may vary in your application. Contact MAXON for information on installation specific estimates or guarantees. No guarantee of emissions is intended or implied without specific written guarantee from MAXON.

Read "Specifications of Series LV AIRFLO® burners" for complete information on these burner types.