

Eclipse ExtensoHeat Lance Burners

*Model EH050
Version 1*

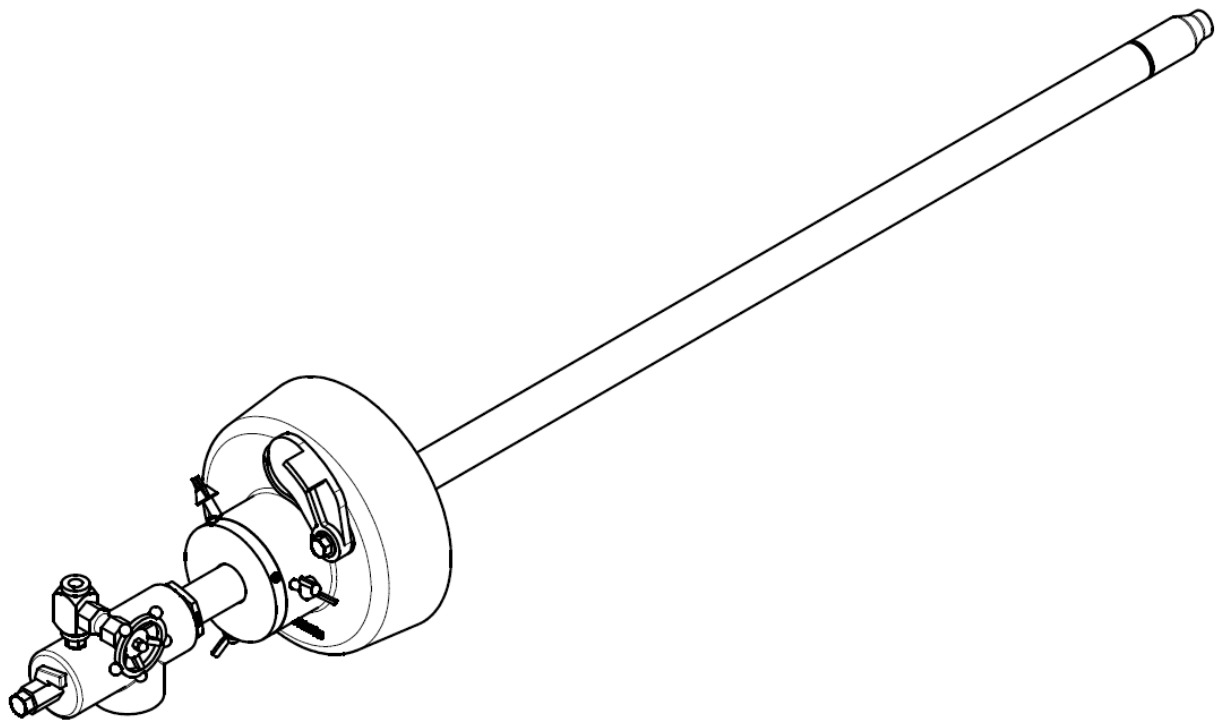

Copyright

Copyright 2007 by Eclipse, Inc. All rights reserved worldwide. This publication is protected by federal regulation and shall not be copied, distributed, transmitted, transcribed or translated into any human or computer language, in any form or by any means, to any third parties, without the express written consent of Eclipse, Inc.

Disclaimer Notice

In accordance with the manufacturer's policy of continual product improvement, the product presented in this brochure is subject to change without notice or obligation.

The material in this manual is believed adequate for the intended use of the product. If the product is used for purposes other than those specified herein, confirmation of validity and suitability must be obtained. Eclipse warrants that the product itself does not infringe upon any United States patents. No further warranty is expressed or implied.

Liability & Warranty

We have made every effort to make this manual as accurate and complete as possible. Should you find errors or omissions, please bring them to our attention so that we may correct them. In this way we hope to improve our product documentation for the benefit of our customers. Please send your corrections and comments to our Marketing Communications Manager.

It must be understood that Eclipse's liability for its product, whether due to breach of warranty, negligence, strict liability, or otherwise is limited to the furnishing of replacement parts and Eclipse will not be liable for any

other injury, loss, damage or expenses, whether direct or consequential, including but not limited to loss of use, income, or damage to material arising in connection with the sale, installation, use of, inability to use, or the repair or replacement of Eclipse's products.

Any operation expressly prohibited in this manual, any adjustment, or assembly procedures not recommended or authorized in these instructions shall void the warranty.

Document Conventions

There are several special symbols in this document. You must know their meaning and importance.

The explanation of these symbols follows below. Please read it thoroughly.

How To Get Help

If you need help, contact your local Eclipse representative. You can also contact Eclipse at:

1665 Elmwood Rd.
Rockford, Illinois 61103 U.S.A.
Phone: 815-877-3031
Fax: 815-877-3336
<http://www.eclipsenet.com>

Please have the information on the product label available when contacting the factory so we may better serve you.

| | |
|--|--|
|  ECLIPSE <small>Innovative Thermal Solutions</small> | www.eclipsenet.com |
| Product Name | |
| Item # | |
| S/N | |
| DD MMM YYYY | |



This is the safety alert symbol. It is used to alert you to potential personal injury hazards. Obey all safety messages that follow this symbol to avoid possible injury or death.



Indicates a hazardous situation which, if not avoided, will result in death or serious injury.



Indicates a hazardous situation which, if not avoided, could result in death or serious injury.



Indicates a hazardous situation which, if not avoided, could result in minor or moderate injury.

NOTICE

Is used to address practices not related to personal injury.

NOTE

Indicates an important part of text. Read thoroughly.



Table of Contents

| | |
|---|-----------|
| Introduction..... | 4 |
| Product Description..... | 4 |
| Audience..... | 4 |
| ExtensoHeat Documents..... | 4 |
| Purpose..... | 4 |
| Safety..... | 5 |
| Introduction..... | 5 |
| Safety..... | 5 |
| Capabilities..... | 5 |
| Operator Training..... | 5 |
| Replacement Parts..... | 5 |
| Installation..... | 6 |
| Introduction..... | 6 |
| Handling..... | 6 |
| Storage..... | 6 |
| Position of Components..... | 6 |
| Approvals of Components..... | 6 |
| Checklist Before Installation..... | 7 |
| General Installation Conditions..... | 7 |
| Burner Installation..... | 7 |
| Piping..... | 9 |
| Valve Installation..... | 9 |
| Checklist After Installation..... | 9 |
| Adjustment, Start, and Stop..... | 10 |
| Introduction..... | 10 |
| Putting Into Operation..... | 10 |
| Adjustment Procedure..... | 10 |
| Step 1: Initial Air Adjustment..... | 10 |
| Step 2: Fuel Gas Adjustment and Regulation..... | 11 |
| Step 3: Air Balancing Adjustment..... | 11 |
| Step 4: Settings Verification..... | 11 |
| Operating Cycle..... | 12 |
| Stop..... | 12 |
| Maintenance and Troubleshooting..... | 13 |
| Introduction..... | 13 |
| Maintenance..... | 13 |
| Monthly Checklist..... | 13 |



Table of Contents

Yearly Checklist 13

Troubleshooting 14

Appendix **i**

 Conversion Factors i

 Key to System Schematics ii

Introduction

1

Product Description

The ExtensoHeat is a nozzle-mixing type burner intended to operate in high-temperature firing kilns with very thick walls and roof. It is also suitable for special applications in which the flame must be developed away from the burner.

The ExtensoHeat is designed to inject the flame through the thick wall in the combustion chamber, discharging a strong jet of hot gases inside it.

The high speed of the combustion gases ensures excellent temperature uniformity and high efficiency of the system, which improves the product quality. The gas velocity can reach 328 ft/sec (100 m/s). There are different nozzle lengths ranging from 31 inches (800mm) to 55 inches (1,400mm).

Burner Specifications:

- Control options include on/off or group modulation and pulse firing. Constant air flow.
- Self ignition by process temperature.
- Flame detection is not necessary (Temperature above 1382°F or 750°C).
- Operability with other fuels.
- Designed to operate with excess gas in chambers with an oxidizing atmosphere ($O_2 > 12\%$ vol.)

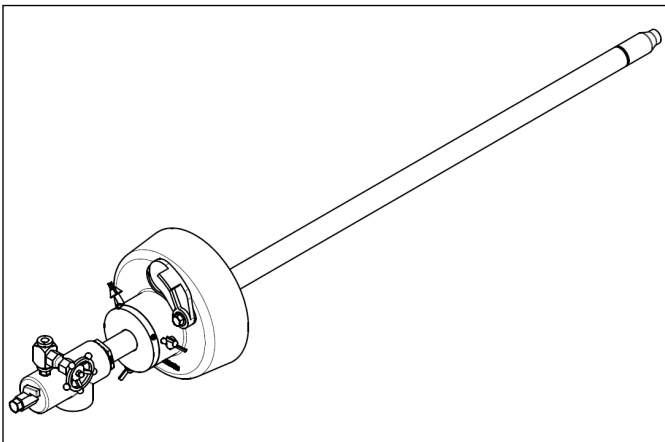

Figure 1.1. ExtensoHeat Burner

Audience

This manual has been written for people who are already familiar with all aspects of a combustion system and its add-on components, also referred to as “the burner system.”

These aspects are:

- Design / Selection
- Installation
- Use
- Maintenance

The audience is expected to have previous experience with this type of equipment.

ExtensoHeat Documents

Design Guide 235

- Used with Datasheet 235 to design the burner system

Datasheet 235

- Required to complete design and selection

Installation Guide 235

- This document

Purpose

The purpose of this manual is to ensure the installation of a safe, effective, and trouble-free combustion system.

Safety

2

Introduction

In this section, you will find important notices about safe operation of a burner system. Read this entire manual before you attempt to start the system.

Safety

DANGER

- **The burners covered in this manual are designed to mix fuel with air and burn the resulting mixture. All fuel burning devices are capable of producing fires and explosions when improperly applied, installed, adjusted, controlled or maintained.**
- **Do not bypass any safety feature. Fires and explosions can be caused.**
- **Never try to light the burner if the burner shows signs of damage or malfunctioning.**

WARNING

- **The burner and duct sections might have HOT surfaces. Always wear protective clothing when approaching the burner.**

NOTICE

- **This manual provides information in the use of these burners for their specific design purpose. Do not deviate from any instructions or application limits described herein without written advice from Eclipse.**
- **Read this entire manual before you attempt to start the system. If you do not understand any part of the information in this manual contact your Eclipse representative or the Eclipse factory before you continue.**

Capabilities

Adjustment, maintenance and troubleshooting of the mechanical and electrical parts of this system should be done by qualified personnel with good mechanical aptitude and experience with combustion equipment.

Operator Training

The best safety precaution is an alert and trained operator. Thoroughly instruct new operators so they demonstrate an adequate understanding of the equipment and its operation. A regular retraining schedule should be administered to ensure operators maintain a high degree of proficiency.

Replacement Parts

Order replacement parts from Eclipse only. All Eclipse approved, customer supplied valves or switches should carry UL, FM, CSA, CGA, and/or CE approval where applicable.

Installation

3

Introduction

In this section you will find important notices about the safe operation of the burner.

Handling

- Make sure the area is clean.
- Protect the components from the weather, damage, dirt and moisture.
- Protect the components from excessive temperatures and humidity.
- Use the appropriate support equipment when lifting the burner components.

Storage

- Make sure the components are clean and free of damage.
- Store the components in a cool, clean, dry room.
- After you have made sure everything is present and in good condition, keep the components in the original package as long as possible.

Position of Components

The position and amount of components is determined by the kind of control method chosen. All the control methods can be found in Design Guide 235. Use the schematics in the System Design section to build your system.

Approval of Components

Limit Controls & Safety Equipment

All limit controls and safety equipment must comply with all applicable local codes and/or standards and must be listed for combustion safety by an independent testing agency. Typical application examples include:

- American: NFPA 86 with listing marks from UL, FM, CSA
- European: EN 746-2 with CE mark from TuV, Gastec, Advantica

Electrical Wiring

All electrical wiring must comply with all applicable local codes and/or standards such as:

- NFPA Standard 70
- IEC60364
- CSA C22
- BS7671

Gas Piping

All gas piping must comply with all applicable local codes and/or standards such as:

- NFPA Standard 54
- ANSI Z223
- EN 746-2

The gas piping must be accepted by local authorities.

Where to Get the Standards:

The NFPA Standards are available from:
National Fire Protection Agency
Batterymarch Park
Quincy, MA 02269
www.nfpa.org

The ANSI Standards are available from:
American National Standard Institute
1430 Broadway
New York, NY 10018
www.ansi.org

The UL Standards are available from:
333 Pfingsten Road
Northbrook, IL 60062
www.ul.com

The FM Standards are available from:
1151 Boston-Providence Turnpike
PO Box 9102
Norwood, MA 02062
www.fmglobal.com/approvals

Information on the EN standards and where to get them is available from:

Comité Européen de Normalisation
Stassartstraat 36
B-1050 Brussels
Phone: +32-25196811
Fax: +32-25196819
www.cen.eu

Comité Européen de Normalisation Electronique
Stassartstraat 36
B-1050 Brussels
Phone: +32-25196871
Fax: +32-25196919
www.cenelec.org

Checklist Before Installation

Intake

To admit fresh combustion air from outdoors, provide an opening in the room of at least one square inch per 3,000 BTU/hr (5 cm² per 1 kW). If there are corrosive fumes or materials in the air, supply the burner with clean air from an uncontaminated area, or provide a sufficient air filtering system.

Exhaust

Do not allow exhaust fumes to accumulate in the work area. Provide some positive means for exhausting fumes from the furnace and the building.

Access

Make sure you install the burner in such a way that you can gain easy access for inspection and maintenance.

Environment

Make sure the burner operating environment matches the original operating specifications. Check the following items:

- Voltage, frequency and stability of the electrical power
- Type and supply pressure of the fuel
- Availability of enough fresh, clean combustion air
- Adequate oxygen concentration for combustion on the process gases
- Humidity, altitude and temperature of the air
- Presence of damaging corrosive gases in the air

General Installation Conditions

Mechanical

Connect the burner feedings with the corresponding manifold using steel piping, or copper in special cases. Weld in accordance with both the country's regulation where the equipment will be installed, and user specific standards as applicable.

Check the following before installing the burner:

- Remove all dirt (dust and other particles) and avoid further soiling during piping and accessory installation.
- Check that there are no obstructions in the burner duct or in the feed piping connections.

Electrical

Install the high-voltage transformer (as applicable) as close to the burner as possible.



WARNING

- Take special care with control and measurement wiring installation and insulation, which must be protected against moisture, electrical induction, etc., while still insuring correct installation grounding.

Burner Installation

Dimensions

For full information on the dimensions, refer to the specific datasheet.

Chamber Wall

Make sure the chamber's wall or roof is strong enough to support the weight of the burner. If necessary, reinforce the area where you plan to install the burner to support the weight of the burner.

Avoid Losses

To make sure air does not go back to the casing of the chamber, it is important that the joint between the roof and the burner plate is sealed with some type of insulation, such as ceramic fiber.

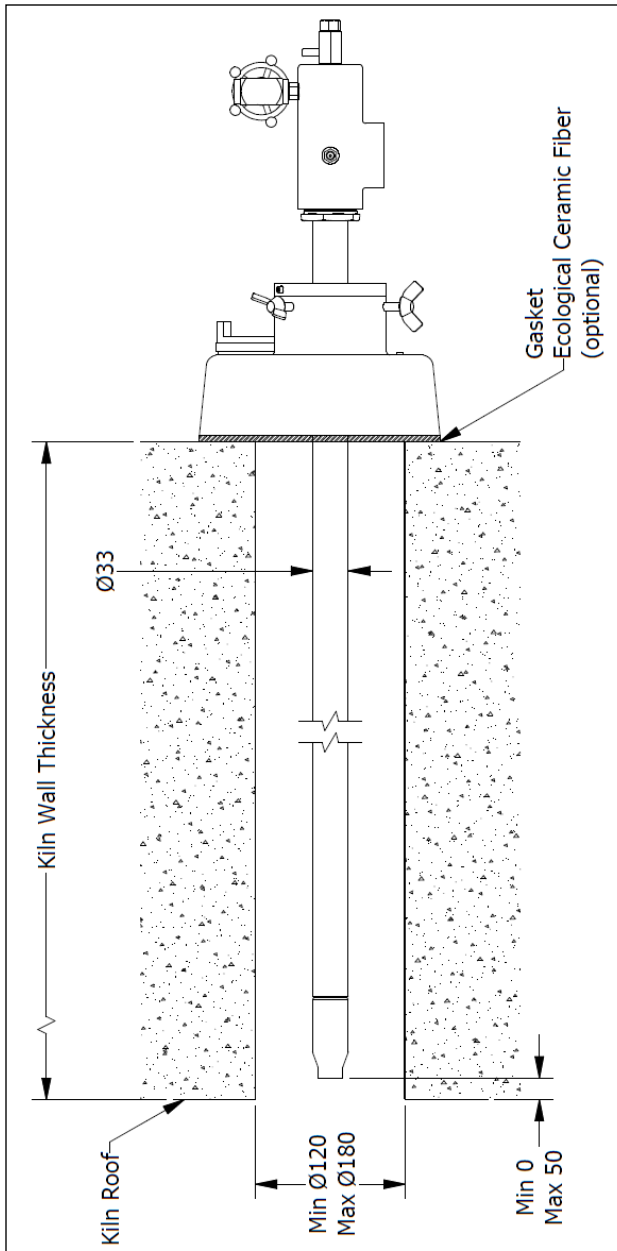

Figure 3.1. ExtensoHeat Burner Installation on the Chamber Roof (Dimensions in mm)

The front plate is supported on the roof and enables the burner to be fixed in place with a retainer ring. The sliding securing system allows each burner to be adapted to the kiln wall or roof thickness where it is installed.

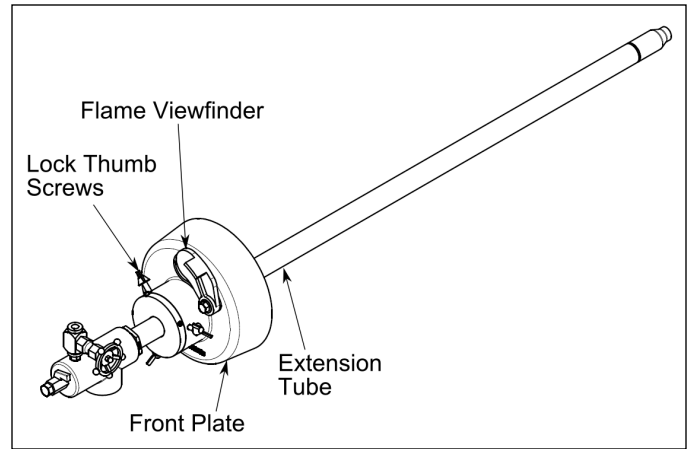

Figure 3.2. ExtensoHeat Burner Front Plate

The hole diameter through the kiln's roof allows ExtensoHeat burners to be installed in case of low temperature level.

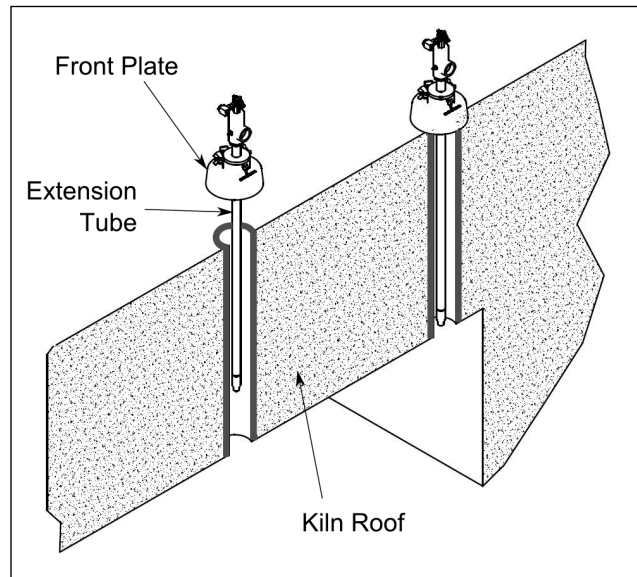

Figure 3.3. ExtensoHeat Burners Distribution

The front plate includes a flame viewport with manual latch. There is a fixation option with a ball, which enables the burner to be orientated within a ten degrees angle, that is available under request.

Installation Conditions

- Check that the burner extension tube is at least 7.9" (200mm) longer than the wall thickness to allow the installation of the front supporting plate.
- Measure the kiln roof or wall thickness and then install the retainer ring so the end of the nozzle is even with interior surface of the kiln roof/wall, or recessed up to a maximum of 2 inches (50mm).



CAUTION

- **Adjust the length of each burner separately in arch kilns.**
 - Settle the front plates on their housings.
 - Install the burners in the kiln taking precaution to firmly tighten the locking wing nuts in the neck of the front plate.
 - The securing rings on the side burners (horizontal position) have to be replaced with sliding flanges that are to be welded in place with a length suitable to the wall thickness.

Piping

Layout

Install the piping as shown in the schematics. Refer to Design Guide 235.

Support the Piping

Use bar supports with height adjustment to support each group of gas and air piping. Consult your local gas company with questions.

Pipe Connections

1. Install a pipe union in the gas line to the burner. This simplifies removal of the burner.
2. The use of flexible pipe nipples in the gas line to the burner is the most common. Flexible nipples can absorb stress due to heat expansion and slight misalignment.

NOTICE

- **Flexible pipe nipples may cause higher pressure drops than an equivalent standard pipe. Consider this when you size the air and gas lines.**

Avoid Large Pressure Drops

NOTE: The pressure drop of the gas in the piping is a critical parameter. Make sure the size of all piping is large enough to prevent excessive pressure losses.

Valve Installation

Valve Orientation

Install all the valves in such a way that the arrow (if present) on the valve body points in the direction of flow.

Gas Cocks

Make sure the handle of the gas cock is at a right angle to the valve body when the valve is in the closed position. This is an important position indicator. If you do not do this,

somebody may think that the gas cock is in the closed position, when it is actually in the open position.

Gas Balancing Valves

A gas balancing valve is typically the same as a manual butterfly valve. For more information, refer to the section below.

Manual Butterfly Valves

Install manual butterfly valves in accordance with Bulletin/Info Guide 720.

Automatic Butterfly Valves

An automatic butterfly valve is driven by an actuator (actuator and mounting bracket not illustrated). Install the control valve in accordance with Bulletin/Info Guide 720.

Adjustable Limiting Orifices

Adjustable limiting orifice valves are used for fine adjustment of gas flow. Install the control valve in accordance with Bulletin/Info Guide 728/730.

Solenoid Valves

Install special solenoid valves for use in pulse control systems in accordance with the manufacturers information.

High Pressure Control Valves

Install high pressure gas control valves as specified in the manufacturer's installation manual.

Checklist After Installation

To verify proper system installation, do the following:

1. Make sure there are no leaks in the fuel lines or the air lines.
2. Make sure all the components of the control system are properly installed. This includes verifying that all switches are installed in the correct location and that the wiring, pressure lines and impulse lines are properly connected.
3. Make sure the blower rotates in the correct direction. If incorrect, have a qualified electrician rewire the blower to reverse its rotation.
4. Make sure all valves are installed in their proper location and correctly oriented relative to the gas or air flow direction.
5. Make sure all safety components are installed and working properly.

Adjustment Start & Stop 4

Introduction

In this chapter you will find instructions on how to adjust a system, start a system and stop a system.



- **Do not bypass any safety features. This can cause fires and explosions.**
- **Obey the safety precautions in the Safety chapter, and read all of this chapter before starting your system.**

NOTE: Adjustment requires two guides: installation guide 235 and Datasheet 235. This chapter refers to the component information explained in Design Guide 235.

Read this chapter thoroughly before proceeding with the system implementation.

Putting into Operation

Preliminary Installation Checks

- Check that the main manual gas valve is closed and then open it.
- Check that the control board temperature parameters are correct.
- Check that the gas pressure is correctly regulated.
- Check that the main control panel switch is ON.
- Check that the kiln recirculation blower group(s) is operating correctly.
- Check that the exhaust blower(s) is operating correctly.
- Check that the chamber temperature is above 1382°F (750°C).
- Check that the kiln sweep and burner permissive activation are correct.
- Reset the group control cabinet (general safeties) if necessary. General safety solenoid valve opening will take place.

NOTE: Eclipse authorized personnel should perform the initial start of all Eclipse burners.

Adjustment Procedure

Follow these steps to adjust the ExtensoHeat system for the first time:

1. Initial air adjustment
2. Fuel gas adjustment and regulation
3. Air balancing adjustment
4. Settings verification

NOTICE

- **This burner requires continuous monitoring during the startup process and while the temperature is below 1382°F (750°C). It is always recommended to operate at higher temperatures.**

NOTE: In tunnel kiln installation, start adjusting the burners located at the beginning of the firing area

Step 1: Initial Air Adjustment

1. Close all manual and automatic gas valves
2. Fully open manual air valves for each burner.
3. Verify that the air balancing valves are 100% open on all burners.
4. Start the blower.
5. Close the manual balancing valves next to the burner to get 4 – 6" w.c. (10 – 15 mbar) at the burner body (Tap A) and to achieve 30-50% of stoichiometric air.

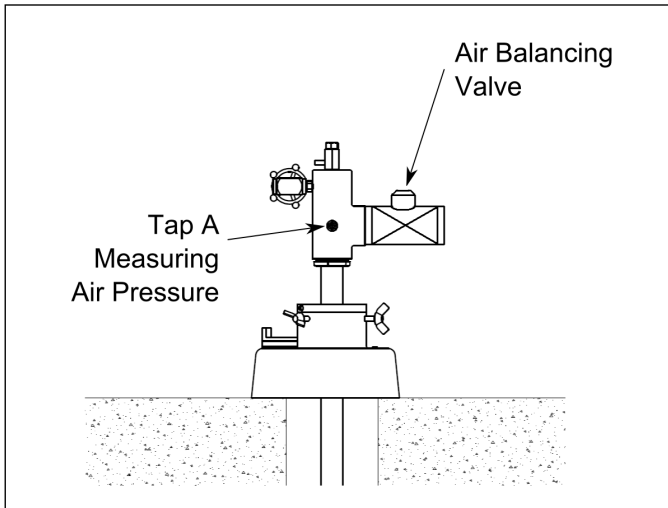

Figure 4.1. Air Adjustment

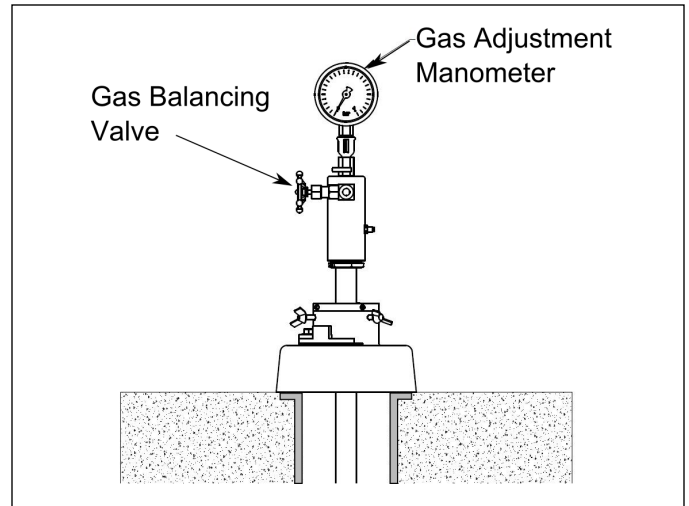

Figure 4.2. Fuel Gas Adjustment

6. Using a manometer, adjust the low-pressure switch air circuit to 50% of the blower pressure.
7. Adjust the air line bypass to maintain a minimum cooling airflow when the air valve is closed

NOTE: Make sure the blower rotates in the correct direction. If incorrect, have a qualified electrician rewire the blower to reverse its rotation.

Step 2: Fuel Gas Adjustment and Regulation

1. Check the gas pressure of selected nozzles on the application.
2. Adjust the gas pressure at the entrance of the group of burners so it corresponds with the pressure level stated in Datasheet 235-1.
3. Adjust the low pressure switch of the gas line to 50-70% of the required inlet pressure.
4. Adjust the high-pressure switch of the gas line to 20% above the inlet pressure to the burners.
5. Fully open the manual gas valve.
6. Fully open the gas balancing valve to the burner.

7. Use the gas curves from the appropriate ExtensoHeat datasheet for the gas being used to find the gas pressure needed at high fire. This is the target value for high fire.
8. Adjust the gas pressure regulator to achieve the target value.
9. Adjust the minimum pressure of the gas bypass to 10% of the high fire pressure or lower if necessary to prevent product damage during cycle advances (if it exists).
10. Repeat steps 3 and 4 for all burners of the group.

Step 3: Air Balancing Adjustment

Adjust the air balancing valve again for each burner to keep the pressure at the selected value (4-6 "w.c. or 10-15 mbar at Tap A)

Step 4: Settings Verification

After several operation cycles, check the chamber temperature homogeneity, and, if necessary, adjust the gas by adjusting the manual balancing valves for each burner separately.

NOTE: When all the settings have been completed, mark the position of the indicator, or lock the balancing valves to hold the valve position.



- If simulated limits do not shut down the fuel system within the required failure response time, immediately correct the problem before proceeding.

Operating Cycle

Firing Zone (in roof)

For each group:

- Manually start the combustion air blower
- Check that the air actuator is closed
- Open the manual air and gas valves for each burner
- Press the main group start button. Air is set to maximum and the burner main group safety solenoid valve opens
- Temperature regulation takes place according to selected type and mode

NOTE: During burner operation, the air flow is always constant. The regulation cycles only take place with “car stopped”. During each “car advance” the main group safety valve closes, and the air actuator closes.

Stop

- Press the group(s) stop button
- Close the main and burner manual gas valve (firing zone in kiln’s roof)
- If the kiln is maintained in operation, remove the burners and close the holes
- In case of kiln stop, do not switch off the combustion blower until the kiln temperature is less than 572°F (300°C) and then close the air valves for each burner
- Switch off the electrical power

NOTE: Keep the blower running after the burner is turned off to protect the burner and other components from any back flow of hot gases.



- **The following must be immediately carried out in case of main power failure:**
- **Close all manual air valves so that the burners are isolated from the distribution manifolds and prevent the return of hot gases through the burners.**
- **In case of a long power failure (more than 15 minutes), the burners should be removed from their positions to prevent them from being exposed to high temperatures for a prolonged period.**
- **Select resistant material for air pipes if there is a possibility of temporary reversal of hot gases.**

Maintenance & Troubleshooting

5

Introduction

This section is divided into two parts. The first part describes the maintenance procedures. The second part identifies problems that may occur and gives advice on how to solve these problems.

Maintenance

Preventative maintenance is the key to a reliable, safe and efficient system. The following are suggested guidelines for periodic maintenance. Burners in severe environments or operational conditions should be checked more frequently.

NOTE: The monthly and yearly lists are an average interval. If your environment is dirty, the intervals may be shorter. Check with the local authorities that have jurisdiction over recommended maintenance schedules.



CAUTION

- Turn off power to burner and controls before proceeding with burner inspection.

Monthly Checklist

1. Test (leak test) safety shut-off valves for tightness of closure.
2. Test air pressure switch settings by checking switch movements against pressure settings and comparing with actual impulse pressure.
3. Visually check ignition cable and connectors.
4. Inspect piping for leaks.
5. Remove, clean and inspect all burners.
6. Make sure the following components are not damaged or distorted:
 - Air tube
 - Gas tube
 - Gas Injector
 - Nozzle
7. If applicable, remove and clean all orifice plates.

Yearly Checklist

Make all the verifications included in the monthly checklist and:

1. Check for proper inlet air/gas ratios (refer to Datasheet 235-1).
2. Test all alarm systems for proper response signals.
3. Check valve motors and control valves for free, smooth action and adjustment.
4. Check for proper operation of the ventilating equipment.
5. Test the interlock sequence of all safety equipment; manually make each interlock fail, ensuring that related equipment closes or stops as specified by the manufacturer.

Troubleshooting

| Problem | Possible Cause | Solution |
|--|---|--|
| Cannot initiate startup sequence | Air pressure switch has not made contact | Check air pressure switch adjustment. Check air filter. Check blower rotation from blower |
| | High gas pressure switch has tripped | Check incoming gas pressure. Adjust gas pressure if necessary. Check pressure switch setting and operation |
| | Low gas pressure switch has tripped | Check incoming gas pressure. Adjust gas pressure if necessary. Check pressure switch setting and operation |
| | Insufficient process temperature | Check the temperature. Increase the temperature if necessary. Check safety thermostat settings and operation |
| | Main power is off | Make sure the power is on to the control system |
| | No power to control unit | Call qualified electrician to investigate |
| Startup sequence runs but burner does not light | Too much gas: Manual gas balancing valves have been opened too far | Check pressures and settings against start-up report and adjust as necessary |
| | Too much gas: Gas pressure out of the main gas pressure regulator is too high | Check start-up setting. If necessary, remove regulator and investigate |
| | Not enough gas: Gas pressure out of the main gas pressure regulator is too low | Check start-up setting. Check regulator and adjust if necessary |
| | Not enough gas: Start gas solenoid valve does not open | Check solenoid valve coil for proper orientation. Replace if necessary |
| | Not enough gas: Gas valve not open | Check wiring to the automatic gas shut-off valve |
| | Not enough gas; pilot solenoid valve does not open | Have a qualified electrician check power supply to solenoid |
| | Not enough pilot gas: Air in the gas line | Check output from the flame safeguard. Open gas cock. Purge gas line |
| | Oxygen and/or temperature levels too low | Stop the installation and verify the design data |
| The low fire flame is weak and unstable | Low fire adjusted too low | Increase low fire gas setting |
| | Not enough gas | Check start-up settings and adjust to increase low gas flow |
| | Not enough air | Check start-up settings. Investigate any changes, i.e. blocked filter, loose connections |
| The burner goes off when it cycles to high fire | Insufficient air (flame too rich) | Check start-up settings. Check that the air filter is clean and replace if required |
| | Insufficient oxygen level | Stop the burner(s) and restore the minimum conditions before putting it back in service |
| | Oxygen and/or temperature levels too low | Stop the installation and verify the design data |
| The burner is erratic and does not respond to adjustment | Internal damage to the burner. Some parts inside the burner may be loose or dirty | Contact Eclipse |

| Problem | Possible Cause | Solution |
|--|--|--|
| The burner is unstable or produces soot or smoke | The air/gas ratio is out of adjustment | Measure all gas pressures and air pressures. Compare to initial start-up settings and adjust where necessary |
| Cannot achieve full capacity | Gas pressure is too low into the main gas pressure regulator | Adjust gas pressure |
| | Gas nozzles clogged | Check and clean |
| | Poor piping practices | Contact Eclipse |



Appendix

Conversion Factors

Metric to English

| From | To | Multiply By |
|--|--------------------------------|-------------------------|
| actual cubic meter/hr (am ³ /h) | actual cubic foot/hr (acfh) | 35.31 |
| normal cubic meter/hr (Nm ³ /h) | standard cubic foot /hr (scfh) | 38.04 |
| degrees Celsius (°C) | degrees Fahrenheit (°F) | (°C x 9/5) + 32 |
| kilogram (kg) | pound (lb) | 2.205 |
| kilowatt (kW) | Btu/h | 3415 |
| meter (m) | foot (ft) | 3.281 |
| millibar (mbar) | inches water column ("w.c.) | 0.402 |
| millibar (mbar) | pounds/sq in (psi) | 14.5 x 10 ⁻³ |
| millimeter (mm) | inch (in) | 3.94 x 10 ⁻² |
| MJ/Nm ³ | Btu/ft ³ (standard) | 26.86 |













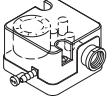
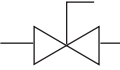

Metric to Metric

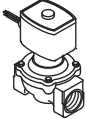
| From | To | Multiply By |
|-------------------|-------------------|-------------|
| kiloPascals (kPa) | millibar (mbar) | 10 |
| meter (m) | millimeter (mm) | 1000 |
| millibar (mbar) | kiloPascals (kPa) | 0.1 |
| millimeter (mm) | meter (m) | 0.001 |

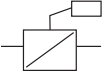
English to Metric

| From | To | Multiply By |
|--------------------------------|--|--------------------------|
| actual cubic foot/hr (acfh) | actual cubic meter/hr (am ³ /h) | 2.832 x 10 ⁻² |
| standard cubic foot /hr (scfh) | normal cubic meter/hr (Nm ³ /h) | 2.629 x 10 ⁻² |
| degrees Fahrenheit (°F) | degrees Celsius (°C) | (°F - 32) x 5/9 |
| pound (lb) | kilogram (kg) | 0.454 |
| Btu/h | kilowatt (kW) | 0.293 x 10 ⁻³ |
| foot (ft) | meter (m) | 0.3048 |
| inches water column ("w.c.) | millibar (mbar) | 2.489 |
| pounds/sq in (psi) | millibar (mbar) | 68.95 |
| inch (in) | millimeter (mm) | 25.4 |
| Btu/ft ³ (standard) | MJ/Nm ³ | 37.2 x 10 ⁻³ |

Key to System Schematics

| Symbol | Appearance | Name | Remarks | Bulletin/ Info Guide |
|---|---|----------------------------------|--|-------------------------|
|  | | ExtensoHeat Burner | | 235 |
|  | | Main Gas Shut-Off Valve Train | Eclipse strongly endorses NFPA as a minimum | 756 |
|  |  | Combustion Air Blower | The combustion air blower provides the combustion air pressure to the burner(s) | 610 |
|  |  | Air Pressure Switch | The air pressure switch gives a signal to the safety system when there is not enough air pressure from the blower | 610 |
|  |  | Gas Cock | Gas cocks are used to manually shut off the gas supply on both sides of the main gas shut-off valve train | 710 |
|  |  | Solenoid Valve (Normally Closed) | Solenoid valves are used to automatically shut off the gas supply on a bypass gas system or on small capacity burner systems | 760 |
|  |  | Manual Butterfly Valve | Manual butterfly valve are used to balance the air or gas flow at each burner, and/or to control the zone flow | 720 |
|  |  | Automatic Butterfly Valve | Automatic butterfly valves are typically used to set the output of the system | |
|  | | Motorized Gas Control Valve | A motorized gas control valve adjusts the gas flow to the burner(s) based on the control system requirements | |
|  |  | Adjustable Limiting Orifice | Adjustable limiting orifices are used for fine adjustment of gas flow | 728/730 |
|  | | Pressure Taps | The schematics show the advised positions of the pressure taps | |

