

Burner control unit BCU 370

Technical Information · GB
6 Edition 11.08l

- For modulating, forced draught burners for gas of unlimited capacity in intermittent or continuous operation
- Control of fan and butterfly valve
- Simple system set-up thanks to optional tightness control and integrated ignition unit
- Easy start-up and maintenance thanks to Manual operating mode
- Optionally available with integral field bus interface for simple wiring
- EC type-tested and certified, CSA and FM approved



Table of contents

| | | | |
|---|-----------|--|-----------|
| Burner control unit BCU 370 | 1 | 3.4.3 Network technology | 31 |
| Table of contents | 2 | 3.4.4 Configuration | 32 |
| 1 Application | 4 | 3.4.5 Bus communication | 32 |
| 1.1 Example applications | 6 | 3.5 Program status | 34 |
| 1.1.1 Modulating-controlled forced draught burner | 6 | 3.6 Fault message (blinking) | 35 |
| 1.1.2 Modulating-controlled forced draught burner with tightness control | 6 | 3.6.1 Reaction to process faults | 36 |
| 1.1.3 Modulating-controlled forced draught burner with pilot burner and tightness control | 7 | 4 Parameters | 38 |
| 1.1.4 Controlling the BCU via PROFIBUS-DP | 8 | 4.1 Scanning the parameters | 40 |
| 1.1.5 Controlling the BCU and the butterfly valve via PROFIBUS-DP | 8 | 4.2 Flame control | 40 |
| 2 Certification | 9 | 4.2.1 Burner flame signal | 40 |
| 2.1 PROFIBUS User Organisation | 9 | 4.2.2 Burner switch-off threshold | 40 |
| 3 Function | 10 | 4.2.3 UVS check (1x in 24 hours) | 40 |
| 3.1 Connection diagrams | 10 | 4.3 Behaviour during start-up | 41 |
| 3.1.1 BCU 370 | 10 | 4.3.1 Minimum burner pause time t_{BP} | 41 |
| 3.1.2 BCU 370 with actuator IC 20 | 14 | 4.3.2 Burner start-up attempts | 41 |
| 3.1.3 Capacity control by adjusting the valve between the Open position and a separate Low position | 15 | 4.3.3 Switch-on delay time t_E | 42 |
| 3.1.4 BCU 370..B1 with PROFIBUS-DP | 16 | 4.3.4 Pre-ignition time t_{VZ} | 42 |
| 3.2 BCU 370 program sequence | 17 | 4.3.5 1 st safety time on start-up, burner/pilot burner t_{SA1} | 43 |
| 3.2.1 Normal start-up | 17 | 4.3.6 1 st flame proving period, burner/pilot burner t_{FS1} | 43 |
| 3.2.2 Quick start, butterfly valve waits in the Ignition position | 19 | 4.3.7 2 nd safety time on start-up, main burner t_{SA2} | 44 |
| 3.2.3 Quick start, butterfly valve waits in the Closed position | 21 | 4.3.8 2 nd flame proving period, main burner t_{FS2} | 44 |
| 3.2.4 Start-up without pre-purge, butterfly valve waits in the Closed position | 23 | 4.4 Behaviour during operation | 45 |
| 3.2.5 Controlled air flow | 25 | 4.4.1 Minimum combustion time t_B | 45 |
| 3.3 Tightness control | 26 | 4.4.2 Controller enable signal delay time t_{RF} | 45 |
| 3.3.1 Program sequence | 28 | 4.4.3 Safety time during operation t_{SB} | 46 |
| 3.4 PROFIBUS-DP | 30 | 4.4.4 Behaviour in the event of flame failure during operation | 46 |
| 3.4.1 Configuration, Master-Slave procedure | 30 | 4.4.5 Last fault signal | 47 |
| 3.4.2 Addressing | 31 | 4.4.6 V2 during burner operation | 47 |
| | | 4.5 Monitoring/tightness control | 48 |
| | | 4.5.1 Min. gas pressure monitoring | 48 |
| | | 4.5.2 Digital input function | 48 |
| | | 4.5.3 Air monitoring during pre-purge | 49 |
| | | 4.5.4 Air monitoring during operation | 50 |
| | | 4.5.5 Tightness test period t_p | 51 |
| | | 4.5.6 Calculation example | 52 |

| | |
|--|-----------|
| 4.6 Air control | 53 |
| 4.6.1 Valve control | 53 |
| 4.6.2 Pre-purge | 53 |
| 4.6.3 Quick start starts in | 54 |
| 4.6.4 Pre-purge time t_{PV} | 55 |
| 4.6.5 Post-purge time t_{PN} | 56 |
| 4.6.6 Fan run up time t_{GV} | 57 |
| 4.7 Control using PROFIBUS-DP | 58 |
| 4.7.1 Bus control activation | 58 |
| 4.7.2 Bus control limitation | 58 |
| 4.8 Manual mode | 60 |
| 4.8.1 Operating time in manual mode | 60 |
| 4.9 Fault messages | 61 |
| 4.9.1 The last 10 fault messages | 61 |
| 4.10 Password | 61 |
| 4.10.1 User-defined password | 61 |
| 5 Selection | 62 |
| 5.1 Type code | 62 |
| 6 Project planning information | 63 |
| 6.1 Cable selection | 63 |
| 6.1.1 Ionisation cable | 63 |
| 6.1.2 UV cable | 63 |
| 6.1.3 Ignition cable | 63 |
| 6.2 Fan control | 63 |
| 6.3 Controlling the butterfly valve | 64 |
| 6.4 Safety interlock (Limits) | 64 |
| 6.5 Too many remote resets | 64 |
| 6.6 Protecting the ignition unit from overload | 64 |
| 6.7 Wiring | 65 |
| 6.7.1 Single-electrode operation with external ignition unit | 65 |
| 6.8 BCU switched off | 65 |
| 6.9 Note on EC or CSA and FM type-examination | 65 |
| 6.10 Contact protection devices | 65 |
| 6.11 Installation | 65 |
| 6.12 Protective circuits | 66 |

| | |
|--|-----------|
| 7 Flame control | 67 |
| 7.1 ... with ionisation sensor | 67 |
| 7.2 ... with UV sensor | 67 |
| 8 Accessories | 68 |
| 8.1 High-voltage cable | 68 |
| 8.2 BCSofT | 68 |
| 8.3 Radio interference suppressed electrode adapters | 68 |
| 8.4 Connection kit BCU 370 | 68 |
| 8.5 Set of stickers BCU 370 | 68 |
| 8.6 Device master data file for BCU 370..B1 | 68 |
| 9 Technical data | 69 |
| 9.1 PROFIBUS-DP | 70 |
| 9.2 Operating controls and dimensions | 71 |
| 10 Legend | 72 |
| 11 Glossary | 73 |
| 11.1 Safety shut-down | 73 |
| 11.2 Fault lock-out | 73 |
| 11.3 Warning signal | 73 |
| 11.4 Timeout 25 s/250 s | 73 |
| 12 Annex | 74 |
| 12.1 Status and fault messages for PROFIBUS-DP | 74 |
| Feedback | 77 |
| Contact | 77 |



BCU 370

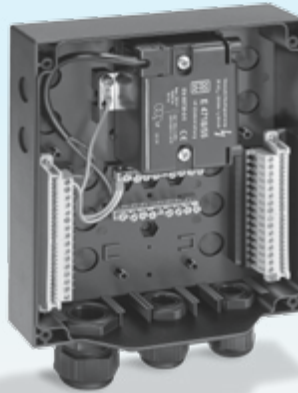

Lower section



Upper section

1 Application

The BCU 370 burner control unit controls, ignites and monitors industrial forced draught burners of unlimited capacity in intermittent or continuous operation.

It can be used for directly ignited forced draught burners or forced draught burners ignited with pilot burner. The BCU 370 activates the fan and sets the connected butterfly valve to Pre-purge and Ignition position. After pre-purge and burner start, the Enable signal is issued to an external controller which positions the butterfly valve in accordance with the output demand. Post-purge occurs after the end of burner operation. The burner control unit BCU 370 monitors the gas and air pressure. An optionally integrated tightness control

function checks the valves with an external gas pressure switch.

Programmability by means of the optical interface and BCSOFT PC software guarantees optimum adaptation to the relevant application. Adjustable start-up attempts and automatic restart which can be activated ensure the high flexibility of the burner equipment.

The quick-start option allows standard-compliant start-up of the forced draught burner without pre-purge after normal shut-down. This avoids unnecessary admission of air into the combustion chamber. The heat output is available as quickly as possible after a temperature demand.



Application

The program status, the unit parameters and the level of the flame signal can be read directly from the BCU. An integrated Manual mode allows manual start of the burner and setting of the butterfly valve position independently of the central control system. The BCSoft operator-control and setting software provides a powerful tool for start-up and servicing.

To reduce the installation and wiring costs Krom-schröder offers an optional Profibus-DP interface to transfer the activation signals and feedbacks.

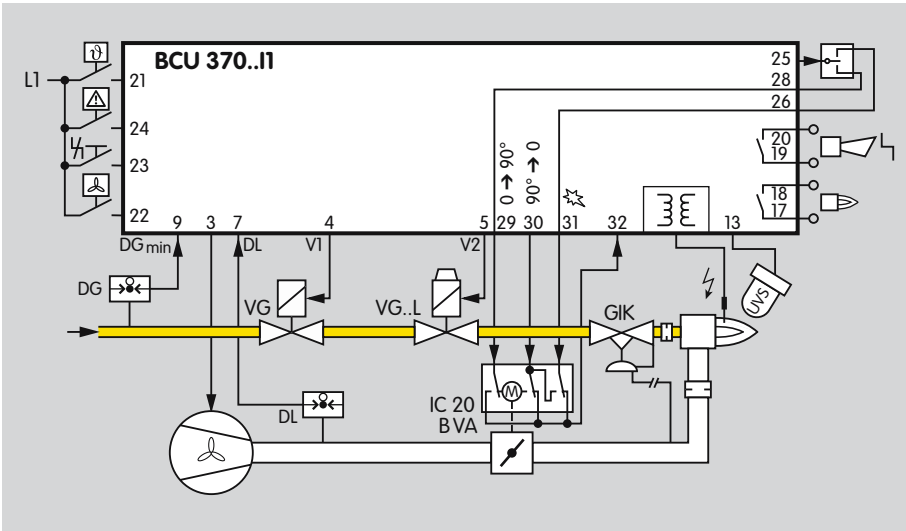

1.1 Example applications

1.1.1 Modulating-controlled forced draught burner

The BCU 370 controls the fan and moves the butterfly valve to pre-purge and ignition position. It issues the Enable signal to the control system after start-up of the burner.

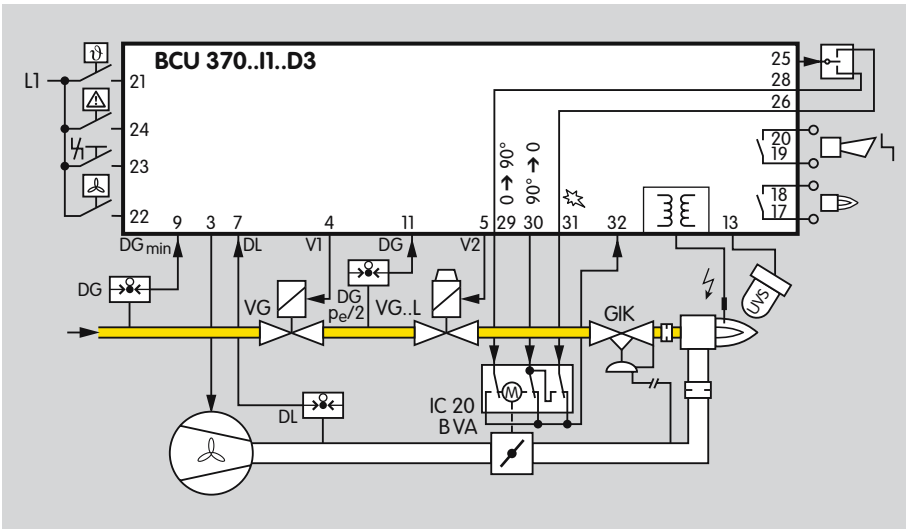

1.1.2 Modulating-controlled forced draught burner with tightness control

In addition to controlling the forced draught burner, the burner control unit also monitors the fail-safe function of the two solenoid valves for gas via the gas pressure switch DG which is set to $p_e/2$.

Parameter 27 = 1: V2 is "ON" during burner operation.

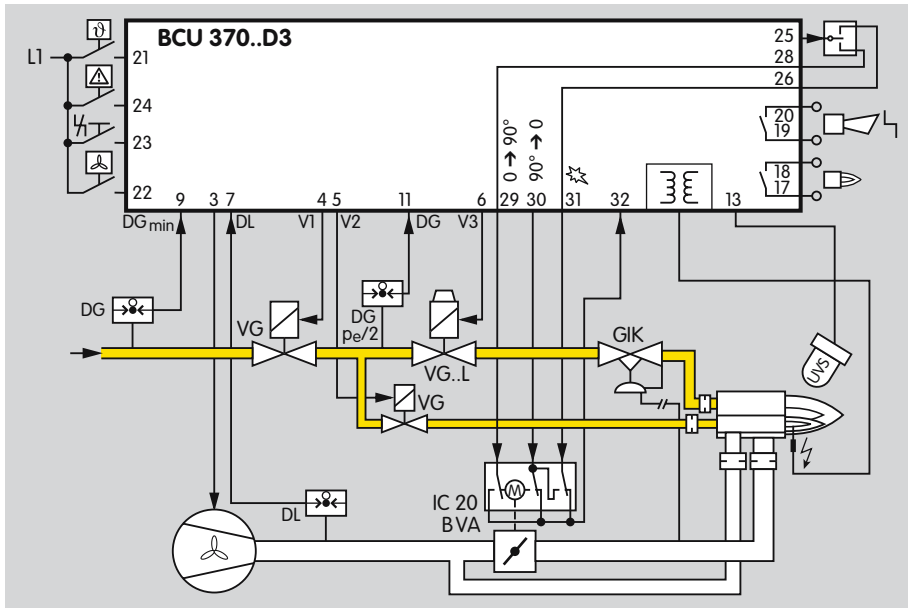

1.1.3 Modulating-controlled forced draught burner with pilot burner and tightness control

A pilot burner ignites the main burner and is switched off during the main burner's safety time.

Parameter 27 = 0: V2 is "OFF", i.e. interrupted pilot burner, during burner operation.

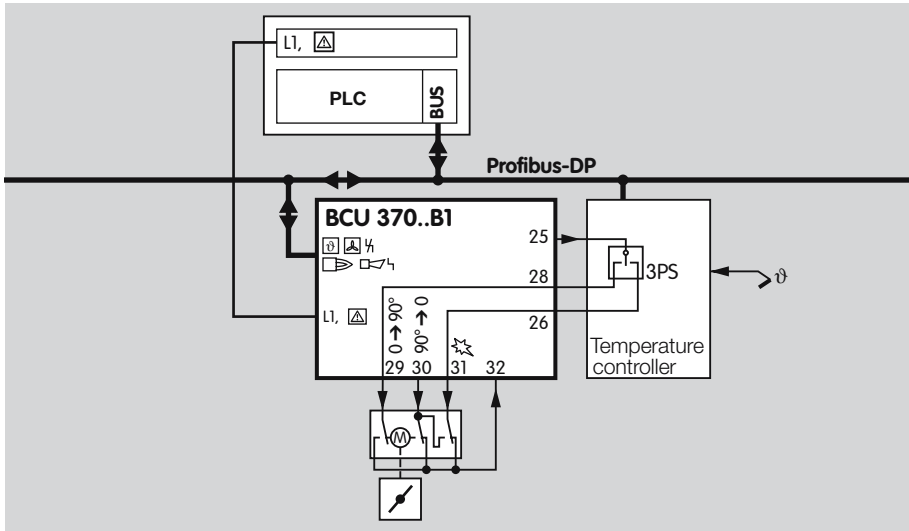

1.1.4 Controlling the BCU via PROFIBUS-DP

The BCU 370..B1 issues the Enable signal to the temperature controller for capacity control. The temperature controller then controls the butterfly valve directly.

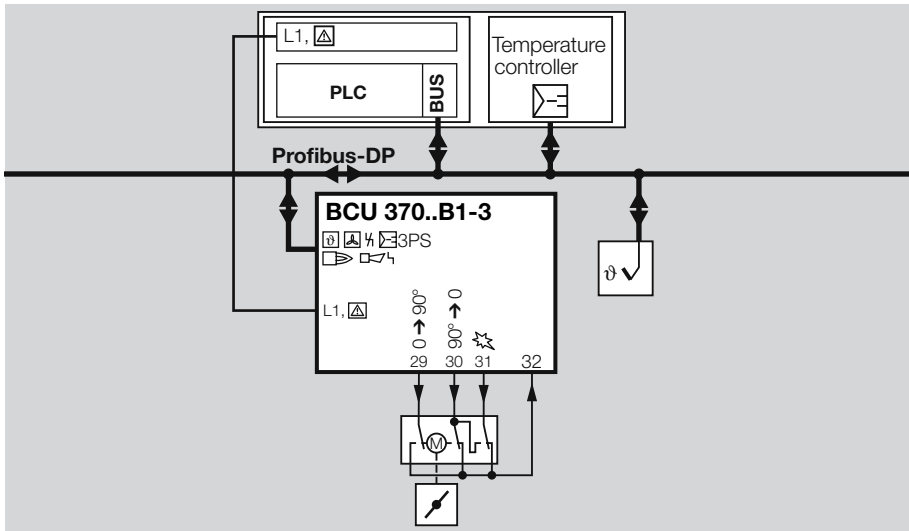

1.1.5 Controlling the BCU and the butterfly valve via PROFIBUS-DP

The BCU 370..B1-3 receives positioning information for the butterfly valve from the temperature controller via the PROFIBUS-DP and activates the butterfly valve following controller enable.



2 Certification

EC type-tested and certified

pursuant to

- Gas Appliances Directive (90/396/EEC) in conjunction with EN 298,
- Low Voltage Directive (73/23/EEC) in conjunction with the relevant standards,
- Electromagnetic compatibility 89/336/EEC in conjunction with the relevant standards relating to radiation.

AGA

Approval No. 6478 in preparation

CSA and FM approved

Canadian Standards Association Class: 3335-01 and 3335-81 Systems (Gas-)Automatic Ignition and Components

Factory Mutual Research Class: 7611 Combustion Safeguards and Flame Sensing System

Suitable for applications pursuant to NFPA 85 and NFPA 86

2.1 PROFIBUS User Organisation

BCU 370..B1

PUO = PROFIBUS User Organisation

Complies with the requirements of EN 50170-2

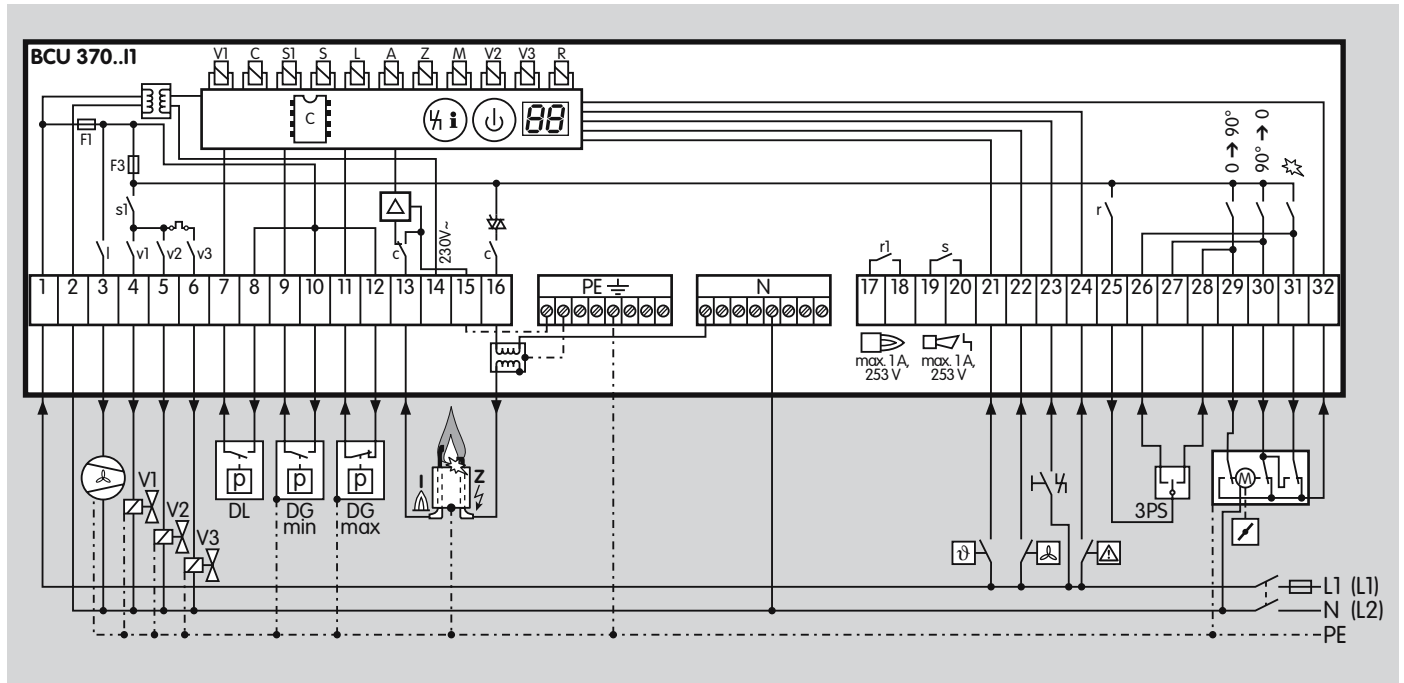

3 Function

For the explanation of symbols, see Legend.



3.1 Connection diagrams

3.1.1 BCU 370

The drawing shows the BCU 370..I1 with integrated ignition unit, ionisation control and double-electrode operation.

For cable selection and wiring, see Project planning information.

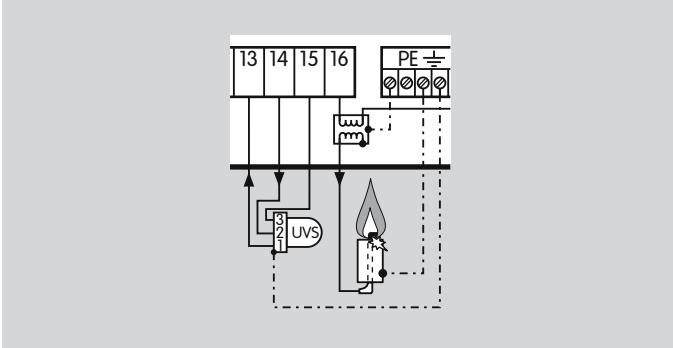

BCU 370..I1 for 120 V and 230 V, UV control

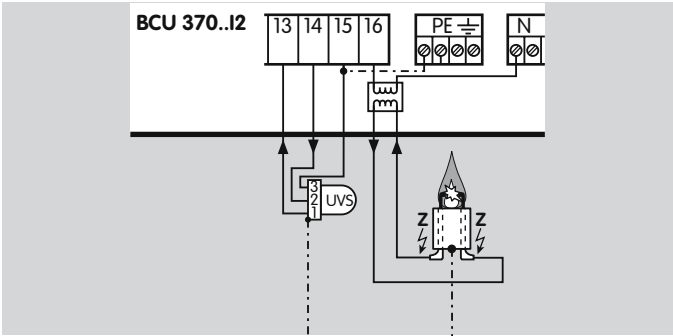

BCU 370..I2 for 230 V, ignition by electrode to electrode

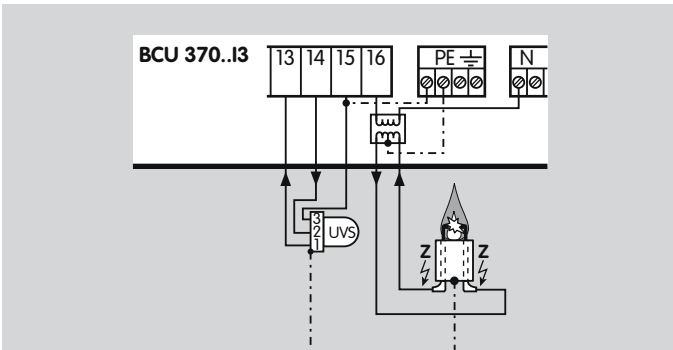

BCU 370..I3 for 120 V, ignition by electrode to electrode with centre tap for secondary earthing



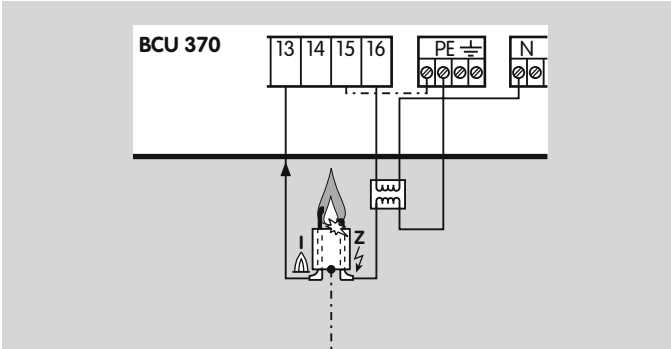

BCU 370 with external ignition transformer, e.g. TZI or TGI.

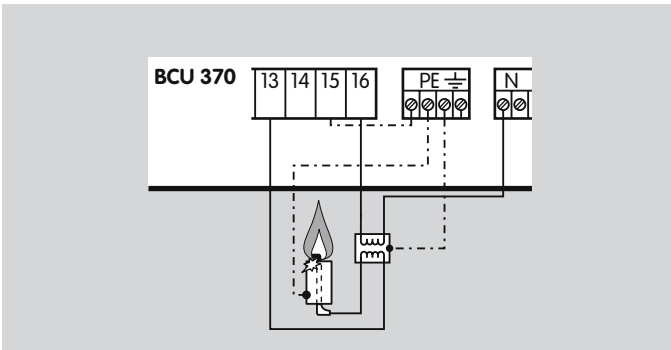

BCU 370 with single-electrode operation, which requires an external ignition transformer TZI or TGI.

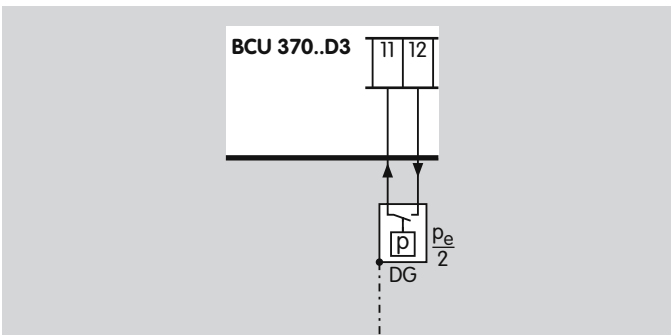

BCU 370..D3, gas pressure switch DG for tightness control



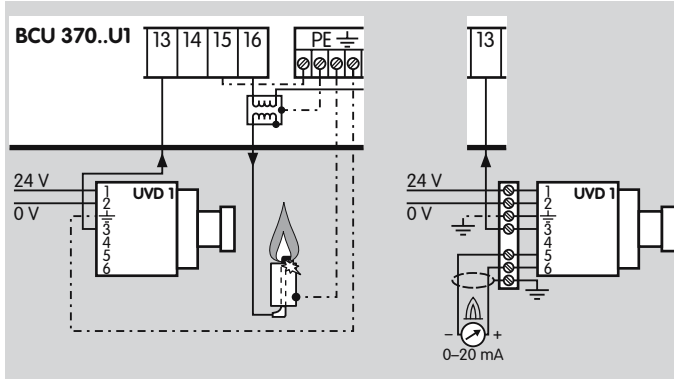

BCU 370..U1 with UV sensor UVD 1 for continuous operation

Connection of the 24 V DC power supply with separate wiring in the lower section of the BCU.

The 0 – 20 mA current output is not required for normal operation. If it is used for the display in a control room for example, then the cable must be connected in the lower section of the BCU, so that the 0 – 20 mA signal can be routed via a screened cable. Length of the unscreened cable from the UV sensor to the BCU: max. 5 m.

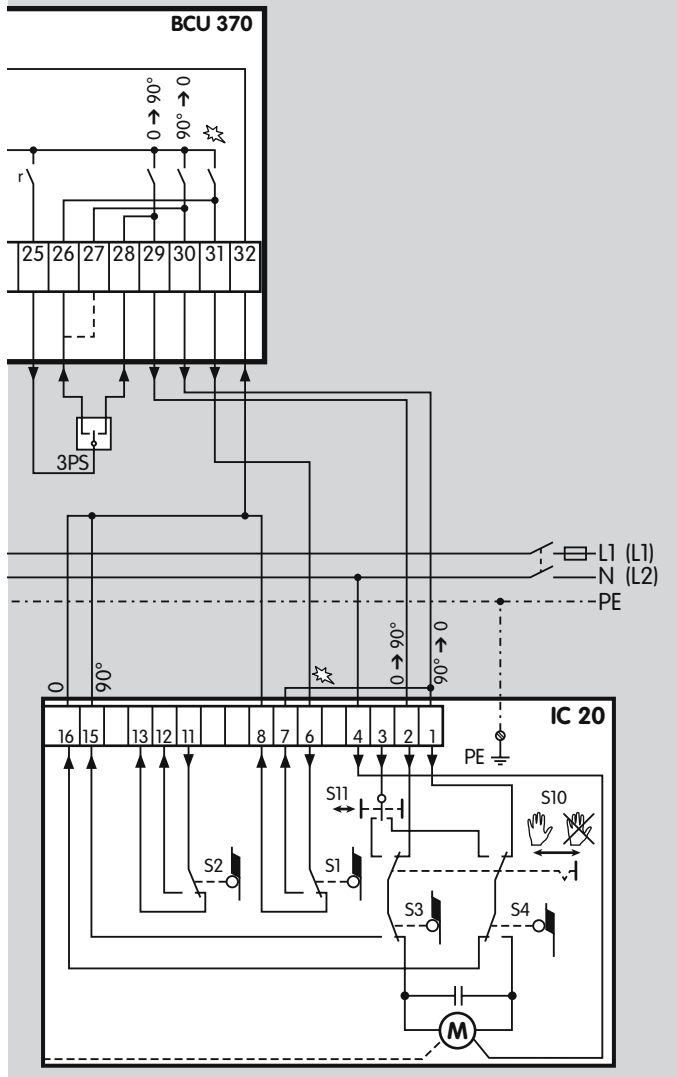

3.1.2 BCU 370 with actuator IC 20

The “closed contact” (90° → 0) of the external three-point step controller (3PS) can be connected to terminal 26 or 27.

Terminal 26: The controller operates between the Open and Ignition positions.

Terminal 27: The controller operates between the Open and Closed positions.

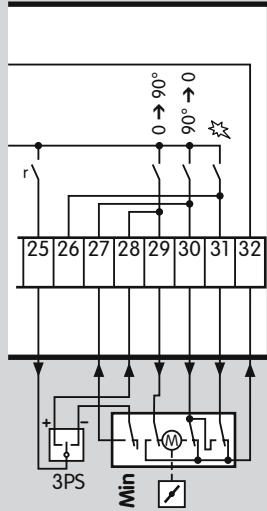

3.1.3 Capacity control by adjusting the valve between the Open position and a separate Low position

This connection is used if the valve position to be approached is below the Ignition position.

Standard wiring of BCU 370 and BCU 370..B1 without three-point step control function

| Valve position | Activation of terminal |
|-----------------------------|---------------------------|
| Upper end position Open | 28 |
| Lower end position Closed | 27 |
| Lower end position Low | Via separate limit switch |
| Lower end position Ignition | 26 |

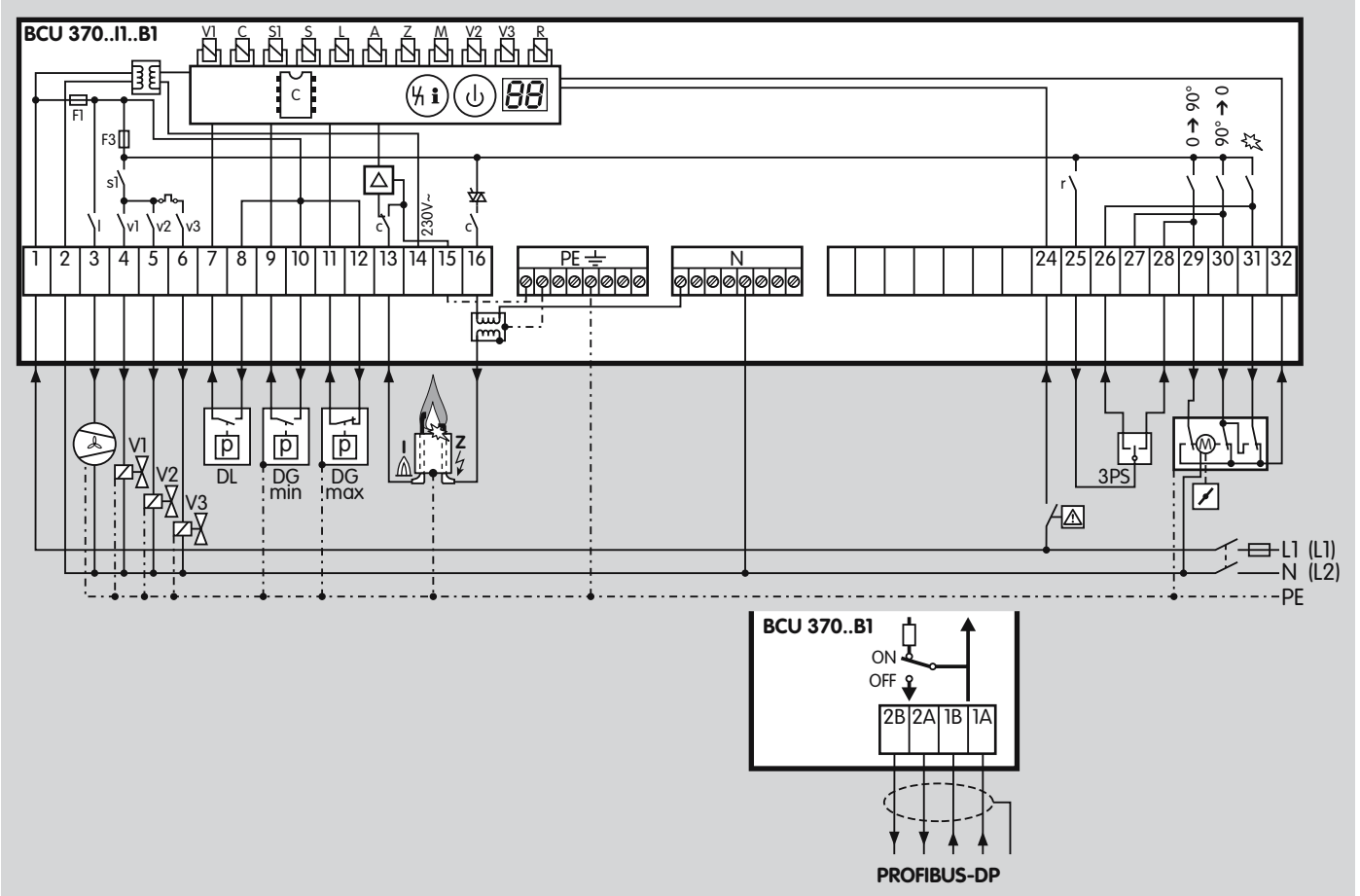

3.1.4 BCU 370..B1 with PROFIBUS-DP

Function see "PROFIBUS-DP"

For cable selection and wiring, see Project planning information.

For the explanation of symbols, see Legend.

3.2 BCU 370 program sequence

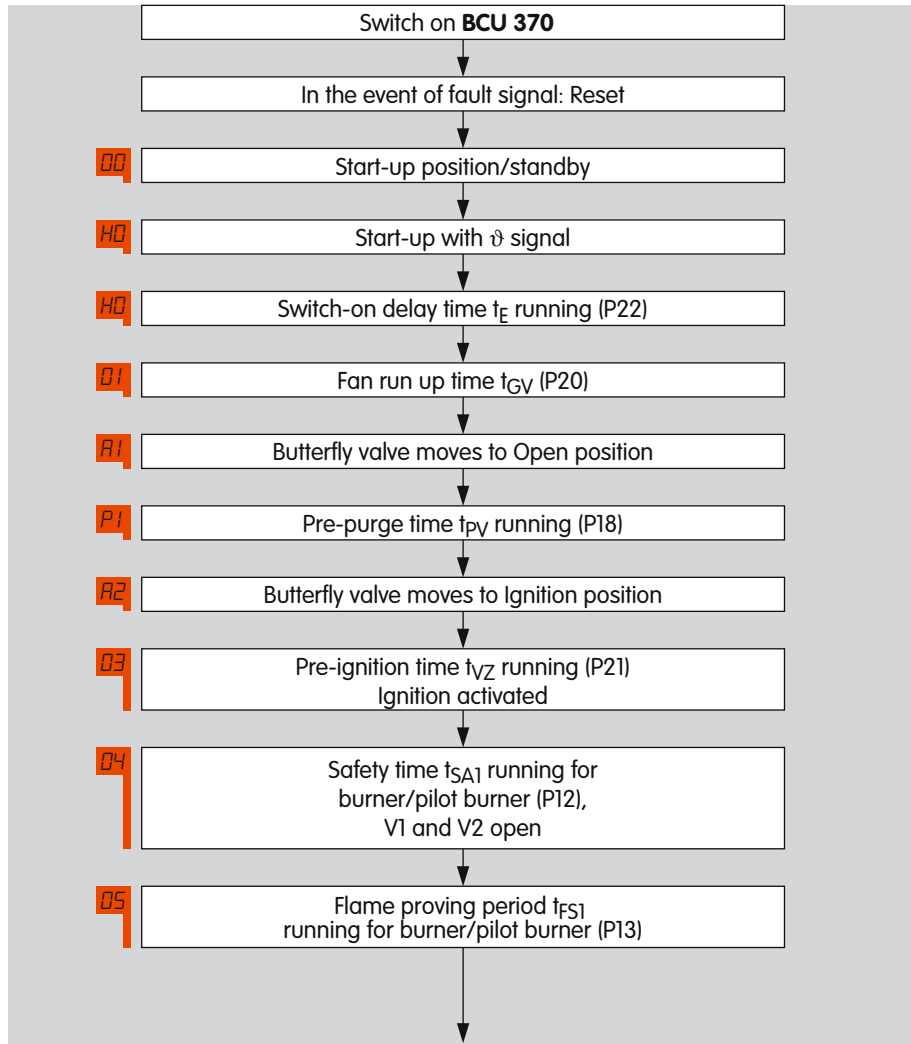

3.2.1 Normal start-up

If a fault from the preceding operating cycle is still being signalled after switching on, it will be necessary to reset this first. Once the start-up signal (ϑ) has been applied, the switch-on delay t_E starts to elapse.

During the fan run up time t_{GV} which follows, the fan starts with the butterfly valve being closed. The butterfly valve then moves from the Closed to the Open position. After pre-purge, it moves back to the Ignition position.

The running times depend on the respective actuator. The BCU waits for actuator feedback before continuing the program sequence.

Now the BCU activates pre-ignition t_{vz} and then opens valves V1 and V2 for the pilot burner. The ignition time t_z is constant. After the flame proving period for the pilot burner t_{FS1} , valve V3 opens to ignite the main burner.



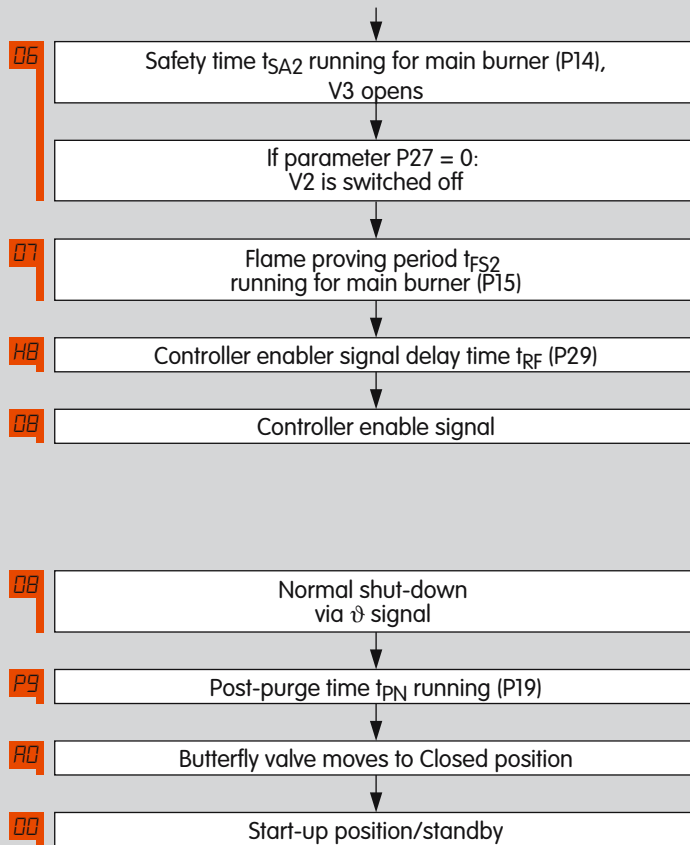

If parameter 27 = 0, V2 closes at the end of the main burner safety time t_{SA2} . The pilot burner is switched off. Then the flame proving period for the main burner t_{FS2} and the controller enable signal delay time t_{RF} start to elapse. Afterwards, the BCU issues the Enable signal to the controller.

If there is no pilot burner, program steps **06** and **07** will be omitted.

As soon as the start-up signal (ϑ) is switched off, post-purge starts. The butterfly valve moves to the Ignition position during this time, then to the Closed position. Next the BCU rests in the start-up position/standby.

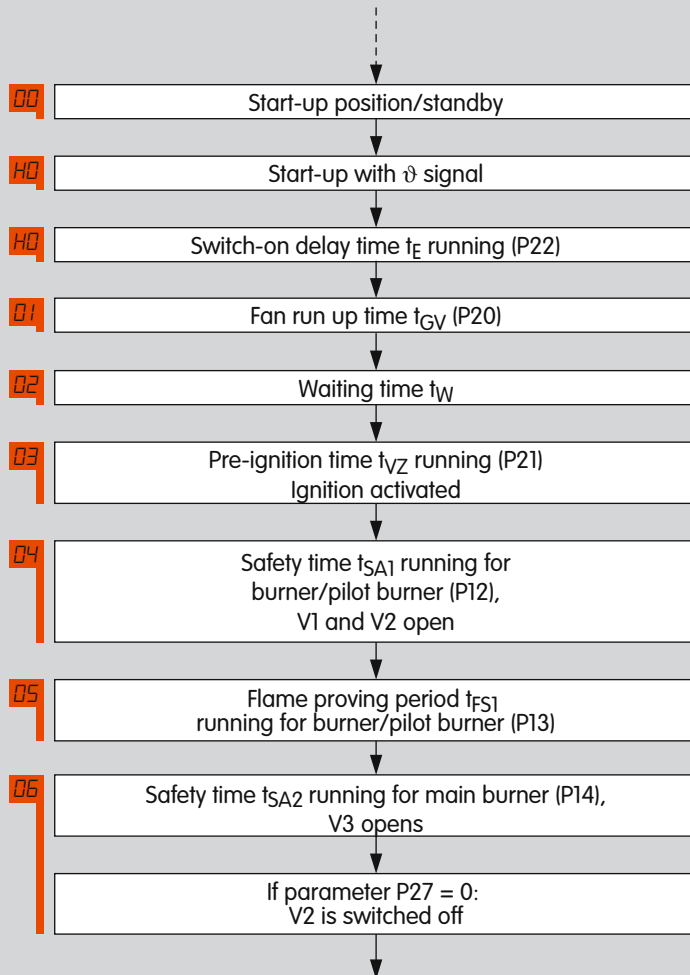

3.2.2 Quick start, butterfly valve waits in the Ignition position

Parameter 06 = 0, parameter 28 = 0

Quick start is the same as normal start, except that pre-purge is dispensed with. The burner starts quicker. This results in improved control quality, since there is no dead time, the energy is used better and no cold air is fed to the combustion chamber.

The BCU 370 only carries out a quick start if the last shut-down was a normal shut-down. No more than 24 hours may have elapsed and the BCU must have been switched on.

In contrast to the “normal start-up”, in the case of a quick start, program steps [R1](#), [P1](#) and [R2](#) will be omitted.

If there is no pilot burner, program steps [06](#) und [07](#) will also be omitted.



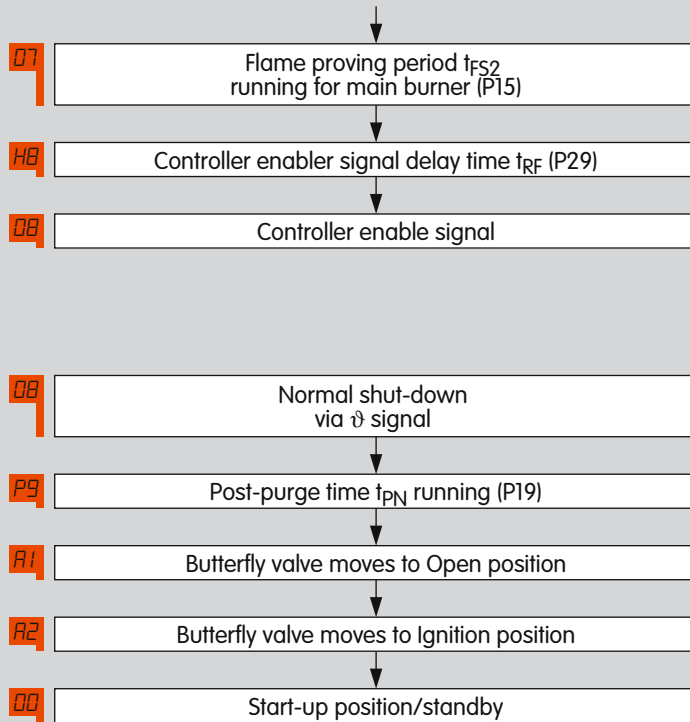

After normal shut-down, the post-purge time t_{PN} starts to elapse and then the butterfly valve moves to the Ignition position in preparation for the next start.

NOTE: Quick Start is not allowed for units with FM or CSA approval.

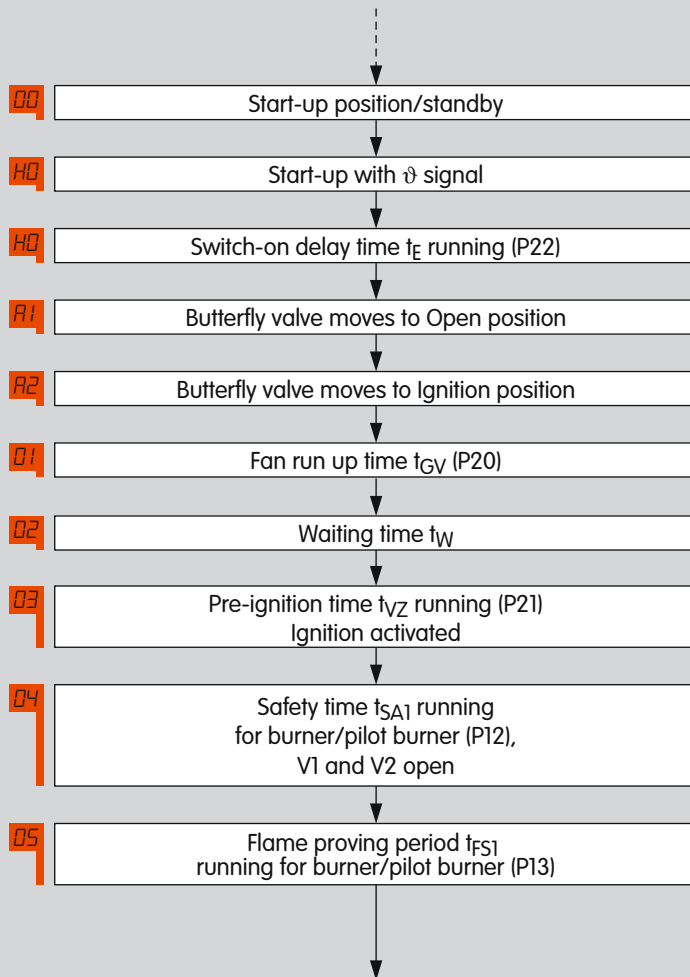

3.2.3 Quick start, butterfly valve waits in the Closed position

Parameter 06 = 0, parameter 28 = 1

Pre-purge will also be omitted for this type of quick start. To prevent cold air from entering the combustion chamber while the BCU is in start-up position/standby, the butterfly valve waits in the Closed position.

The BCU 370 only carries out a quick start if the last shut-down was a normal shut-down. No more than 24 hours may have elapsed and the BCU must have been switched on.

After the switch-on delay time t_E , the butterfly valve moves to the Ignition position. The Ignition position is always approached from the top. Therefore, the butterfly valve moves to the Open position first.



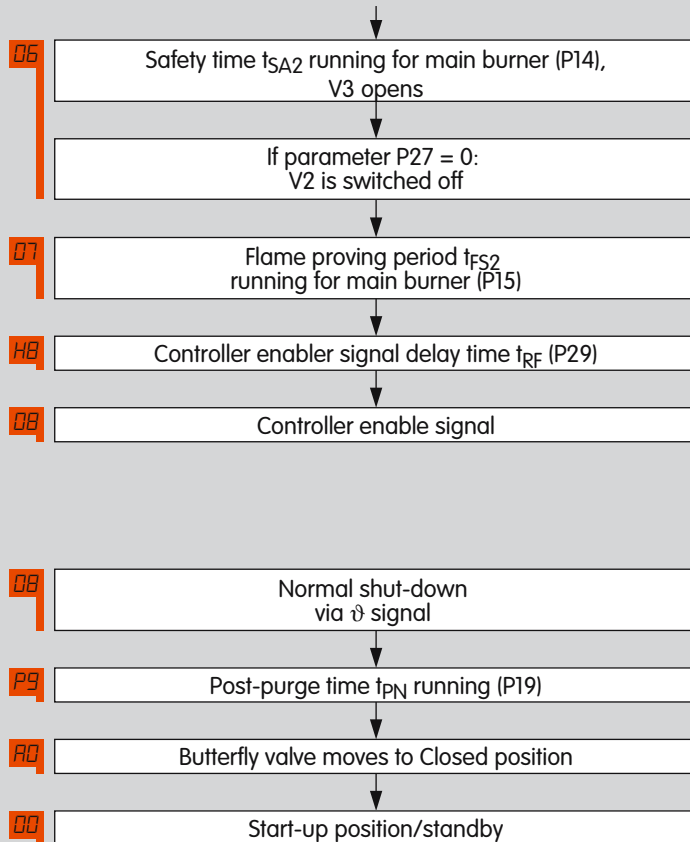

If there is no pilot burner, program steps 06 and 07 will be omitted.

As soon as the start-up signal (ϑ) is switched off, post-purge starts. The butterfly valve moves to the Ignition position during this time, then to the Closed position. Next the BCU rests in the start-up position/standby.

NOTE: Quick Start is not allowed for units with FM or CSA approval.

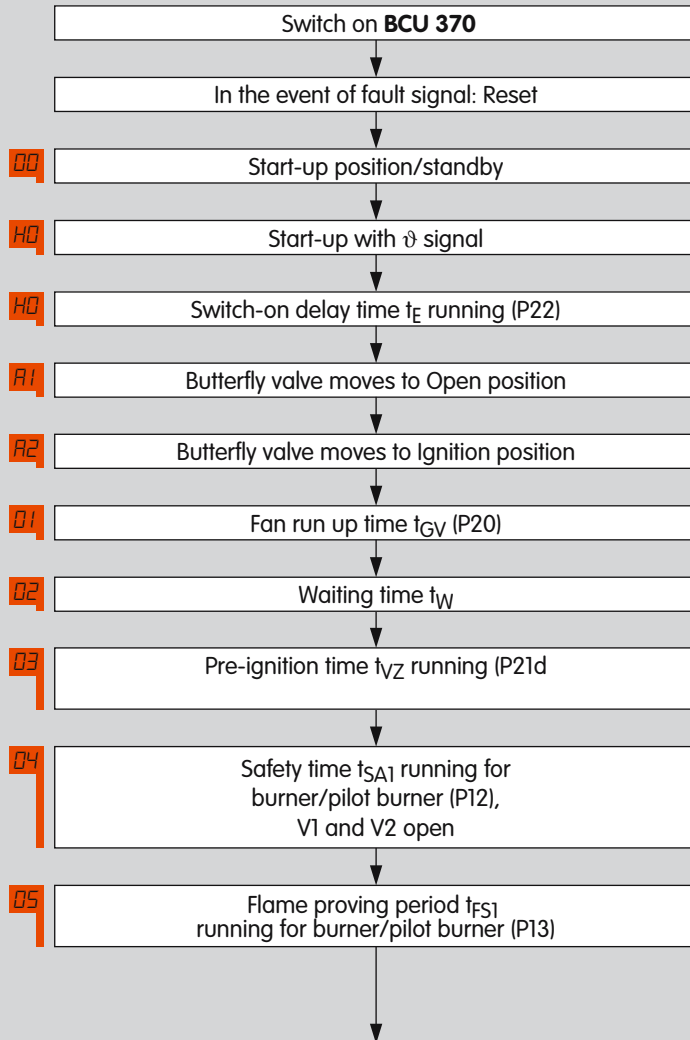

3.2.4 Start-up without pre-purge, butterfly valve waits in the Closed position

Parameter 18 = 0, parameter 28 = 1

If a fault from the preceding operating cycle is still being signalled after switching on, it will be necessary to reset this first. Once the start-up signal (ϑ) has been applied, the switch-on delay t_E starts to elapse.

Afterwards, the butterfly valve moves from the Closed to the Open position and then to the Ignition position. During the fan run up time t_{GV} which follows, the fan starts with the butterfly valve being set to Ignition position.

After the waiting time t_W , the BCU activates pre-ignition t_{VZ} and then opens valves V1 and V2 for the pilot burner. The ignition time t_Z is constant. After the flame proving period for the pilot burner t_{FS1} , valve V3 opens to ignite the main burner.



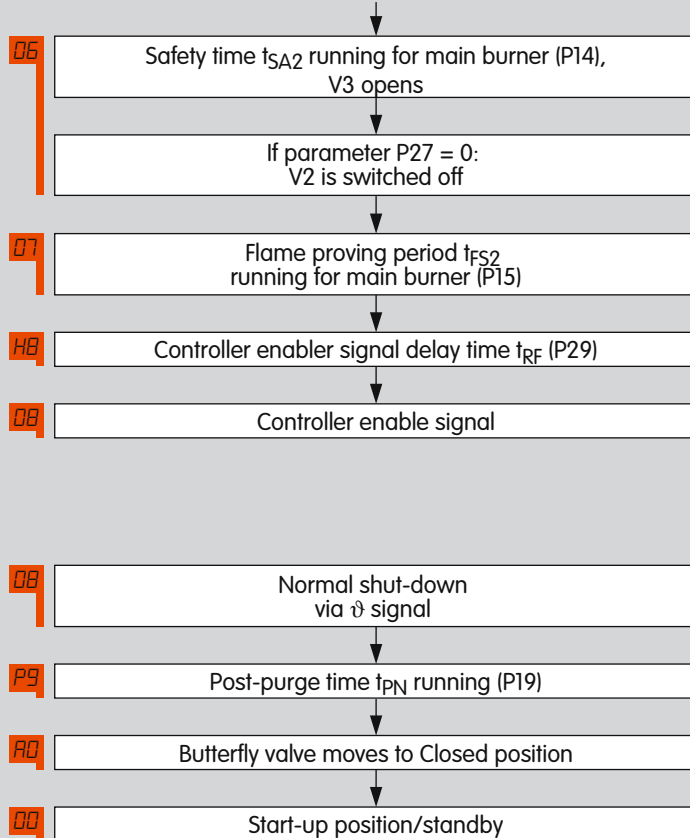

If parameter 27 = 0, V2 closes at the end of the main burner safety time t_{SA2} . The pilot burner is switched off. Then the flame proving period for the main burner t_{FS2} and the controller enable signal delay time t_{RF} start to elapse. Afterwards, the BCU issues the Enable signal to the controller. If there is no pilot burner, program steps 06 and 07 will be omitted.

As soon as the start-up signal (ϑ) is switched off, post-purge starts. The butterfly valve moves to the Ignition position during this time, then to the Closed position. Next the BCU rests in the start-up position/standby.

NOTE: Quick Start is not allowed for units with FM or CSA approval.

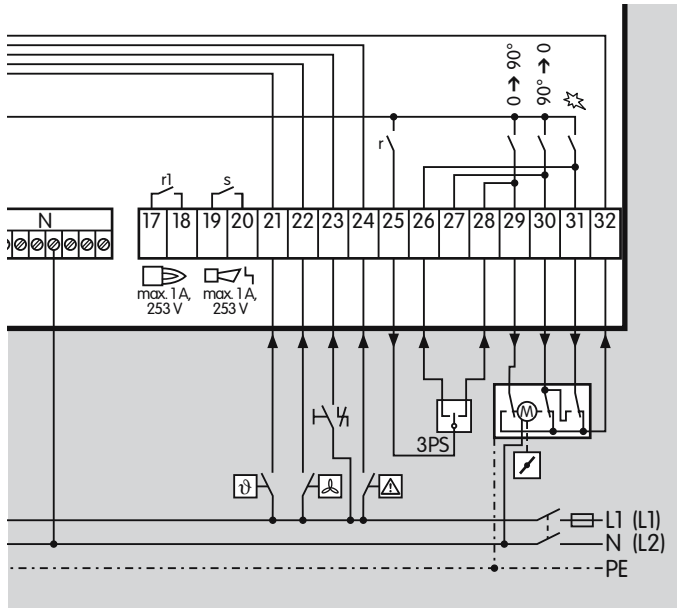

3.2.5 Controlled air flow

The controlled air flow function is enabled when the controlled air flow input, terminal 22 or via PROFIBUS, is activated. Cold air is fed to the combustion chamber, e.g. for cooling.

Following the air pressure switch DL rest position check, the BCU 370 starts the fan and opens the butterfly valve to the Open position. The pressure switch for air DL monitors the air pressure.

If the start-up signal (ϑ) is applied during controlled air flow, the burner is started. If the elapsed controlled air flow time is at least as long as the set pre-purge time, the burner starts immediately after the Ignition position has been approached. If it is shorter, the total air volume is supplied until the end of the pre-purge time.

Activation of the controlled air flow input is not required for normal burner start.

Activation of the controlled air flow function during burner operation will be ignored.

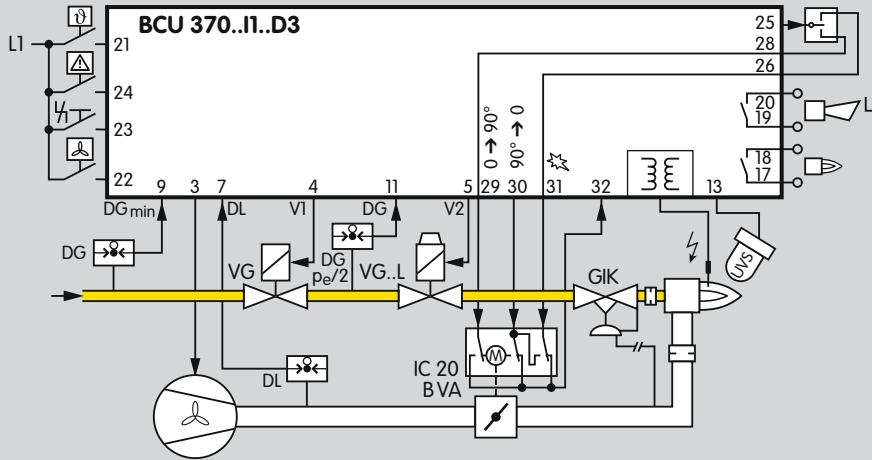

3.3 Tightness control

On BCU 370..D3, the tightness control monitors the fail-safe function of the gas solenoid valves if parameter 24 is set to 3.

The aim of the tightness control is to identify an inadmissible leak on one of the gas solenoid valves and to prevent burner start. The other gas solenoid valve continues working properly and takes over the safe shut-off of the gas supply.

The test takes place during pre-purge. The fan runs and the air pressure opens the air/gas ratio control GIK.

In the case of quick start (parameter 06 = 0), the test takes place after burner operation during post-purge. The pre- and post-purge times (parameters 18 and 19) must be set so that their duration is at least as long as the test period t_p .



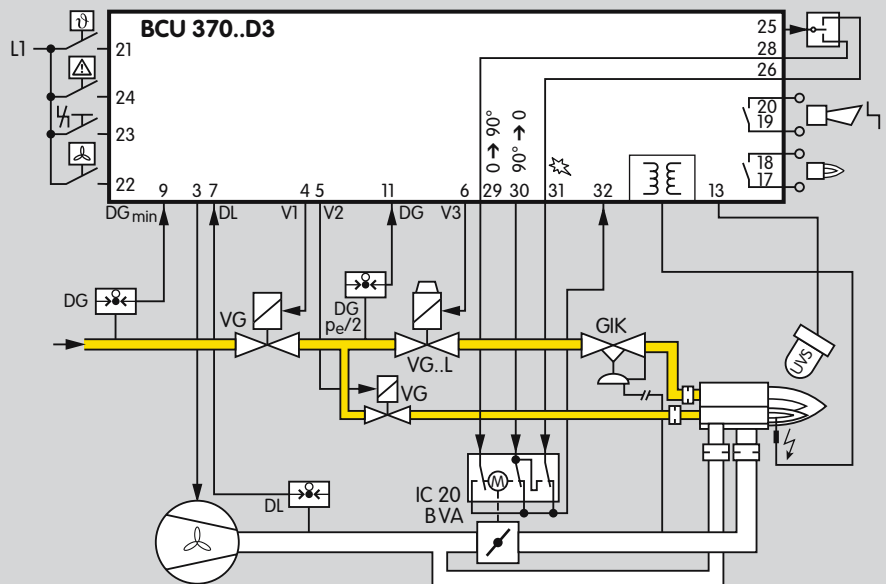

Downstream of the gas solenoid valve V2 on the burner side, the pipe to the burner must be open so that the space between valves V1 and V2 can be vented.

The pressure switch DG monitors the pressure between the two valves. It must be set to half of the inlet pressure $p_e/2$ in order to check both valves with equal sensitivity.

In pilot/main burner systems with three gas solenoid valves, V2 and V3 are checked simultaneously.

TEST

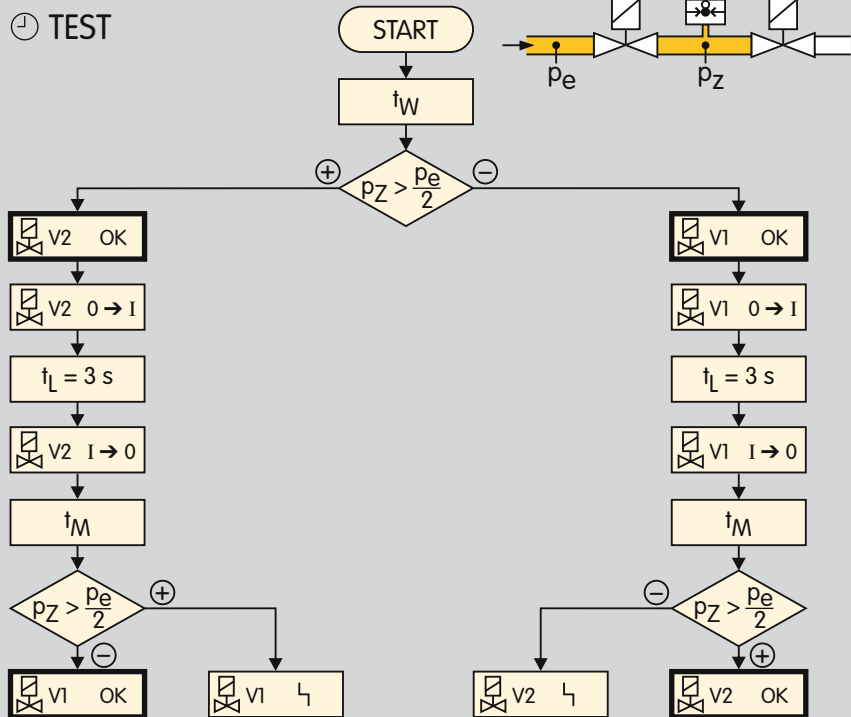

3.3.1 Program sequence

The program flow chart explains the process during the TEST phase.

After start-up the waiting time t_W starts to elapse. Then either the left or right path is executed.

- If the interspace pressure p_Z is greater than half of the inlet pressure $p_e/2$ after the waiting time t_W , V2 is tight. V2 is opened for a duration of 3 seconds to vent the interspace. Then the measurement time t_M starts to elapse. If no interspace pressure can be measured after this time, V1 is also tight. Both valves have thus been checked.
- If no interspace pressure p_Z can be measured after the waiting time t_W , V1 is tight. Then V1 is opened for 3 seconds to fill the space between the valves. Then the measurement time t_M starts to elapse. If a pressure can be measured in the interspace after this time, V2 is also tight. Both valves have thus been checked.



Leakage is indicated by 36 for the first valve and 37 for the second.

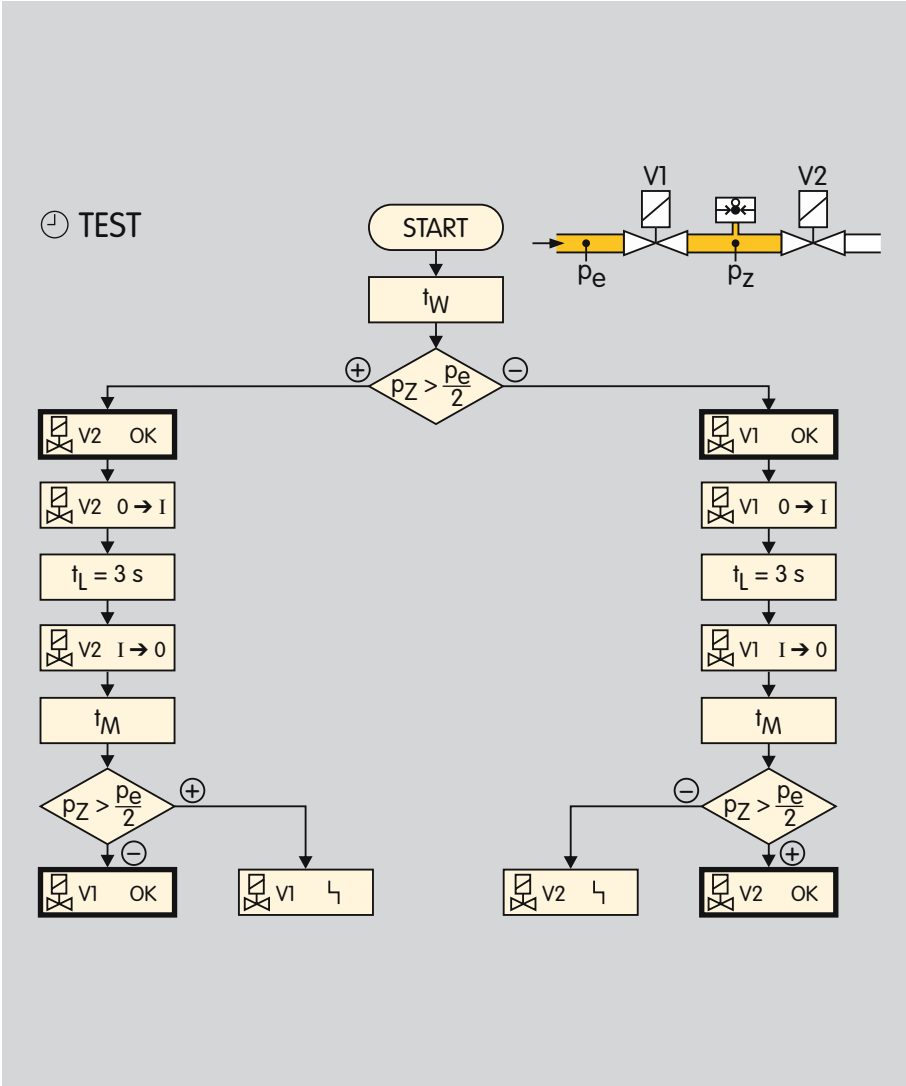

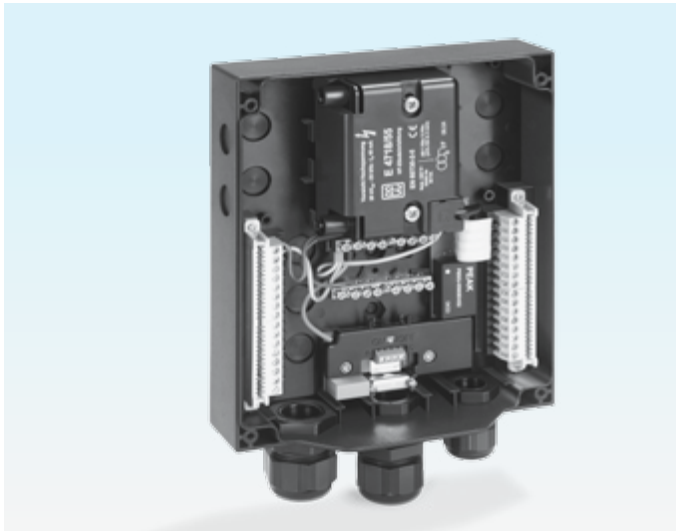
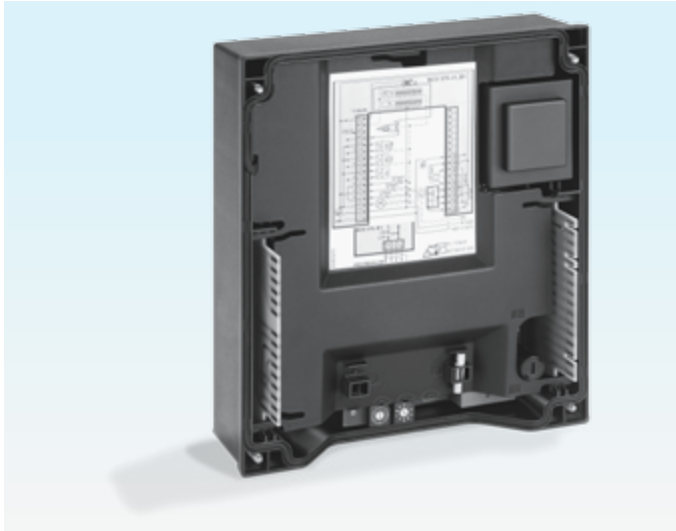

3.4 PROFIBUS-DP

PROFIBUS is a manufacturer-independent, open field bus standard for diverse applications. PROFIBUS-DP is a bus variant for communication between automation systems and distributed peripherals at the field level, optimised for speed and low connection costs.

On PROFIBUS-DP, the individual bus stations are connected via a 2-core shielded cable as standard.

3.4.1 Configuration, Master-Slave procedure

PROFIBUS-DP is structured as a Master-Slave system. This allows mono-master or multi-master systems to be implemented.

A distinction is made between three device types:

- DP Master Class 1 (DPM1)
DPM1 devices are central controllers which exchange data with the distributed stations (slaves) on the basis of a defined cycle. This includes, for instance, the PLC, PC, CNC or VME systems with which the PROFIBUS-DP is operated.
- DP Master Class 2 (DPM2)
DPM2 devices are programming, project planning or operator-control devices. They are used for configuration and commissioning of the system or for system operation and visualisation in ongoing operation.



Function

– DP Slaves

The devices which transmit input information from the periphery to the master and which issue output information from the master to the periphery are referred to as “slaves”.

This also includes the BCU..B1.

The use of a standard bus system offers massive benefits compared to manufacturer-specific bespoke solutions. Time-tested hardware components, standardised connection methods and a series of tools of bus diagnostics and optimisation are available on the market from a whole range of manufacturers. The widespread use of the system ensures that the planning and service personnel are very familiar with how the system operates and how to handle it and can therefore operate the system efficiently.

3.4.2 Addressing

A maximum of 126 units (masters and slaves) can be connected to a PROFIBUS-DP system. Each station is assigned an individual PROFIBUS address which can be set between 0 and 126 using two code switches on the BCU..B1 board.



The left switch sets the tens or hundreds for the address, whilst the right switch sets the units.

3.4.3 Network technology

All devices are connected in a bus structure (line). Up to 32 stations (masters or slaves) can be connected in a single segment. The beginning and end of each segment is fitted with an active bus terminator. Both bus terminators must have a permanent power supply to ensure error-free operation. The bus terminator can be switched in the lower section of the unit.

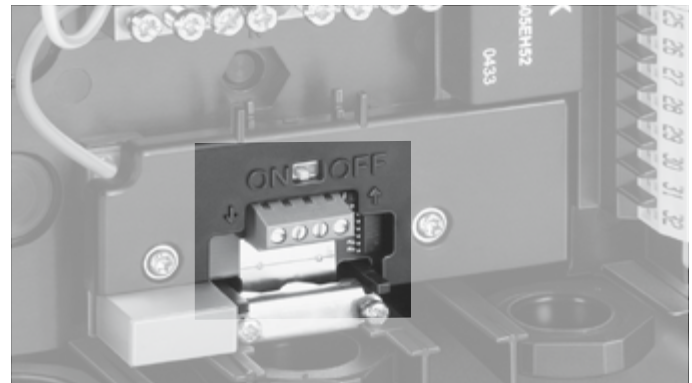

If more than 32 stations are implemented or if there is a need to expand the network area, repeaters (amplifiers) must be used to link the individual bus segments.

3.4.4 Configuration

When planning a PROFIBUS-DP system, unit-specific parameters of each station are to be taken into account.

To allow for simple and standardised planning, the parameters of the BCU..B1 have been summarised in a so-called device master data file (DMD). The file structure is standardised so that it can be read by the planning units of different manufacturers.

The DMD file can be downloaded from www.docuthek.com, once you have registered, or is available on diskette (see Accessories). The steps required to copy the file are described in the instructions for the automation system.

3.4.5 Bus communication

| Input bytes (BCU -> master) | | | | |
|-----------------------------|--------------------------|----------|--|--|
| Bit | Byte 0 | Byte 1 | Byte 2 | Byte 3 |
| 0 | Burner operation | Reserved | Status and fault messages (see Table) | 0 – 25.5 µA of the burner 255 steps |
| 1 | | | | |
| 2 | Fault lock-out | | | |
| 3 | Controlled air flow | | | |
| 4 | Open position reached* | | | |
| 5 | Closed position reached* | | | |
| 6 | ON | | | |
| 7 | Manual mode | | | |

| Output bytes (master -> BCU) | |
|------------------------------|---------------------|
| Bit | Byte 0 |
| 0 | Reset |
| 1 | Start-up |
| 2 | Controlled air flow |
| 3 | |
| 4 | |
| 5 | |
| 6 | Open* |
| 7 | Close* |

* Only on BCU 370..B1-3, three-point step control via PROFIBUS-DP



Function

I/O bytes: The programmer can choose the data to be transferred.

| | Inputs | Outputs |
|-----------------------|--------|---------|
| BCU 370, basic I/O | 1 byte | 1 byte |
| BCU 370, standard I/O | 4 byte | 1 byte |

Baud rate: Up to 1500 kbit/s.

The max. range per segment depends on the baud rate:

| Baud rate [kbit/s] | Range [m] |
|--------------------|-----------|
| 93.75 | 1200 |
| 187.5 | 1000 |
| 500 | 400 |
| 1500 | 200 |

The specified ranges may be increased by using repeaters. No more than three repeaters should be connected in series.

The specified ranges relate to bus cable type A (two-core, shielded and twisted), e.g. Siemens, Order No.: 6XV1830-0EH10 or Lapp cable unitronic, Order No.: 2170-220T.

3.5 Program status

| Display | Program status |
|---------|---|
| 00 | Start-up position/standby |
| R0 | Butterfly valve moves to Closed position |
| d0 | Air monitor rest position check |
| 01 | Fan run up time t_{GV} |
| R1 | Butterfly valve moves to Open position |
| d1 | Air monitor operating position check |
| P1 | Pre-purge time t_{pV} |
| R2 | Butterfly valve moves to Ignition position |
| 02 | Waiting time t_W |
| 03 | Pre-ignition time t_{VZ} |
| 04 | 1 st safety time on start-up t_{SA1} |
| 05 | 1 st flame proving period t_{FS1} |
| 06 | 2 nd safety time on start-up t_{SA2} |
| 07 | 2 nd flame proving period t_{FS2} |
| H8 | Controller enable signal delay time |
| 08 | Operation/Controller enable |
| H0 | Waits for switch-on delay or min. pause time |
| E1 | Controlled air flow |
| P9 | Post-purge time t_{pN} |

In manual mode, two dots blink on the display.

3.6 Fault message (blinking)

| Fault message (blinking) | Display | Fault lock-out | Safety shut-down | Warning signal |
|---|---------|----------------|------------------|----------------|
| Flame simulation | 01 | ● | | |
| Start-up without flame signal | 04 | ● | | |
| Flame failure during 1 st flame proving period | 05 | ● | | |
| Flame failure during 2 nd safety time | 06 | ● | | |
| Flame failure during 2 nd flame proving period | 07 | ● | | |
| Flame failure during operation | 08 | ● | | |
| Too many remote resets | 10 | ● | | |
| Safety interlock failure | 50 | | ● | |
| Permanent remote reset | 52 | | | ● |
| Timing cycle too short | 53 | | ● | |
| DG _{min.} oscillating | 55 | | | ● |
| Bus module error | 6E | | ● | |
| Bus fault | Pb | | | |
| Open + Close set simultaneously | 56 | | | ● |
| Fault Valve feedback | 35 | ● | | |
| Tightness control: V1 leaking | 36 | ● | | |
| Tightness control: V2/V3 leaking | 37 | ● | | |
| Fault Air monitor break contact check | d0 | ● | | |
| Fault Air monitor make contact check | d1 | ● | | |
| Fault Air supply during pre-purge | dP | ● | | |
| Fault Air supply in program step X | dX | ● | | |
| Fault DG _{max.} in program step X | oX | ● | | |
| Fault DG _{min.} in program step X | uX | | ● | |
| Butterfly valve closed position not reached | R0 | ● | | |
| Butterfly valve open position not reached | R1 | ● | | |
| Butterfly valve ignition position not reached | R2 | ● | | |

3.6.1 Reaction to process faults

The BCU 370 reacts differently to process faults in different program steps. If, for example, the signal from air pressure switch DL drops during pre-purge, **d1** flashes on the display and a timeout time of 25 seconds starts to elapse. If the signal is not applied again, the BCU carries out three further start-up attempts.

| Signal (terminal) | Process fault | | BCU 370's reaction | | | | | | |
|-------------------------|------------------------------------|--|--------------------|--------------|--------------------------|------------------|---------------------------------|-----------------------|---------------|
| | Signal status | During program step | Normal shut-down | Timeout 25 s | Immediate fault lock-out | Safety shut-down | Start-up attempts ¹⁾ | Restart ²⁾ | Fault message |
| DG _{max.} (11) | drops | XX All | | | ● | | | | 0X |
| DG _{min.} (9) | drops | XX All except t _{SA1} + t _{SA2} | | | | ● ⁴⁾ | | | uX |
| | not pending after t _{SA1} | 04 t _{SA1} | | | | ● ⁴⁾ | | | u4 |
| | not pending after t _{SA2} | 06 t _{SA2} | | | | ● ⁴⁾ | | | u6 |
| DL (7) | pending | d0 Rest position check | | ● | ● | | | | d0 |
| | not pending | d1 Operating position check | | ● | | | ● | | d1 |
| | drops | P1 Pre-purge time | | ● | | | ● | | dP |
| | drops | P2 Valve moves to Ignition position | | | | ● | ● | | d2 |
| | drops | 02 Waiting time | | | | ● | ● | | d2 |
| | drops | 03 Pre-ignition time | | | | ● | ● | | d3 |
| | drops | 04 t _{SA1} | | | | ● | ● | | d4 |
| | drops | 05 t _{FS1} | | | | ● | ● | | d5 |
| | drops | 06 t _{SA2} | | | | ● | ● | | d6 |
| | drops | 07 t _{FS2} | | | | ● | | ● | d7 |
| | drops | H8 Controller enable waiting time | | | | ● | | ● | d8 |



| Process fault | | | | BCU 370's reaction | | | | | | |
|-----------------------|------------------------------------|----|--|--------------------|--------------|--------------------------|------------------|---------------------------------|-----------------------|---------------|
| Signal (terminal) | Signal status | | During program step | Normal shut-down | Timeout 25 s | Immediate fault lock-out | Safety shut-down | Start-up attempts ¹⁾ | Restart ²⁾ | Fault message |
| DL (7) | drops | 08 | Operation | | | | ● | | ● | d8 |
| | drops | c1 | Controlled air flow | | ● | | | ● | | dP |
| ϑ (21) | drops | XX | All except t _{SA1} + t _{SA2} | ● | | | | | | |
| | drops | 04 | t _{SA1} | ● ³⁾ | | | | | | |
| | drops | 06 | t _{SA2} | ● ³⁾ | | | | | | |
| Safety interlock (24) | drops | XX | All | | | | ● ⁶⁾ | | | S0 |
| Flame (13) | pending | d0 | Rest position check | | ● | ● | | | | d1 |
| | pending | d1 | Operating position check | | ● | ● | | | | d1 |
| | pending | P1 | Pre-purge time | | ● | ● | | | | d1 |
| | pending | R2 | Valve moves to Ignition position | | ● | ● | | | | d1 |
| | pending | 02 | Waiting time | | ● | ● | | | | d1 |
| | not pending after t _{SA1} | 04 | t _{SA1} | | | | ● | ● | | 04 |
| | drops | 05 | t _{FS1} | | | | ● | ● | | 05 |
| | drops | 06 | t _{SA2} | | | | ● | ● | | 06 |
| | drops | 07 | t _{FS2} | | | | ● | | ● | 07 |
| | drops | H8 | Controller enable waiting time | | | | ● | | ● | 08 |
| | drops | 08 | Operation | | | | ● | | ● | 08 |

¹⁾ According to parameter 07. If the last start-up attempt fails, a fault lock-out occurs.

²⁾ According to parameter 08. If the restart fails, a fault lock-out occurs.

³⁾ Safety time elapses completely.

⁴⁾ BCU restarts as soon as the signal is applied again.

⁵⁾ The program sequence is blocked.

⁶⁾ 4) and 5)

4 Parameters

| Description | Parameter | Value range | Default | Adjustable ¹⁾ |
|--|-----------|--|-----------|--------------------------|
| Burner flame signal | 01 | 0 – 25 μ A | | |
| Burner switch-off threshold | 02 | 1 – 20 μ A | 1 μ A | ○ |
| Last fault signal | 03 | XX | | |
| Air monitoring during pre-purge | 04 | 0 = Off; 1 = On | 1 | ● |
| Air monitoring during operation | 05 | 0 = Off; 1 = On | 1 | ● |
| Pre-purge | 06 | 0 = Quick start; 1 = On each start-up | 1 | ● |
| Burner start-up attempts | 07 | 1 – 4 | 1 | ● |
| Behaviour in the event of flame failure during operation | 08 | 0 = Fault lock-out; 1 = Restart | 0 | ● |
| Safety time during operation t_{SB} | 09 | 1; 2 s | 1 s | ● |
| Minimum combustion time t_B | 10 | 0 – 250 s | 0 s | ● |
| Minimum burner pause time t_{BP} | 11 | 0 – 250 s | 0 s | ● |
| 1 st safety time on start-up, burner/pilot burner t_{SA1} | 12 | 2; 3; 5; 10 s | 5 s | ● |
| 1 st flame proving period, burner/pilot burner t_{FS1} | 13 | 0; 2; 5; 10; 20 s | 2 s | ● |
| 2 nd safety time on start-up, main burner t_{SA2} | 14 | 0; 2; 3; 5; 10 s | 3 s | ● |
| 2 nd flame proving period, main burner t_{FS2} | 15 | 0; 2; 5; 10; 20 s | 2 s | ● |
| Operating time in manual mode | 16 | 0 = Unlimited; 1 = Limited to 5 minutes | 1 | ● |
| UVS check (1 x in 24 hours) | 17 | 0 = Off; 1 = On | 0 | ● |
| Pre-purge time t_{PV} | 18 | 0 – 250 s | 30 s | ● |
| Post-purge time t_{PN} | 19 | 0 – 250 s | 0 s | ● |
| Fan run up time t_{GV} | 20 | 0 – 25 s | 2 s | ● |



Parameters

| Description | Parameter | Value range | Default | Adjustable ¹⁾ |
|--|-----------|--|---------|--------------------------|
| Pre-ignition time t_{VZ} | 21 | 0 – 5 s | 1 s | ● |
| Switch-on delay time t_E | 22 | 0 – 250 s | 0 s | ● |
| Min. gas pressure monitoring | 23 | 0 = Off; 1 = On | 1 | ● |
| Digital input function | 24 | 0 = – 1 = DG_{max} . 3 = Tightness control. | 1 | ○ |
| Valve control | 25 | 0 = Off; 1 = On | 1 | ● |
| Tightness test period t_p | 26 | 10; 20; 30 – 250 s | 10 s | ○ |
| V2 during burner operation | 27 | 0 = Off; 1 = On | 0 | ● |
| Quick start starts in | 28 | 0 = Ignition position; 1 = Closed position | 0 | ● |
| Controller enable signal delay time t_{RF} | 29 | 0; 10; 20; 30 – 250 s | 0 s | ● |
| User-defined password | 30 | 0000 – 9999 | XXXX | ● ²⁾ |
| Bus control activation (on BCU..B1-3) | 31 | 0 = Off; 1 = On | 1 | ○ |
| Bus control limitation (on BCU..B1-3) | 32 | 0 = Closed position 1 = Low position 2 = Ignition position | 2 | ○ |
| The last 10 fault messages | 81 – 90 | XX | | |

¹⁾ Adjustable using BCSof software and a PC opto-adapter.

²⁾ Will not be displayed.

● = Adjustable

○ = Depends on hardware configuration

4.1 Scanning the parameters

During operation, the 7-segment display shows the program status.

The flame signal and all following parameters of the BCU can be scanned one after the other by repeatedly pressing the Reset/Information button (for 1 second).

The parameter display is ended 60 seconds after the last time the button is pressed or by switching off the BCU.

The BCU 370 indicates  when the mains switch has been switched off. This signals standby mode. On the BCU 370..B1, the bus switch is still operational to maintain the function of the communication system. The control outputs of the BCU (valves, ignition unit) are electrically separated from the mains voltage.

4.2 Flame control

4.2.1 Burner flame signal

Parameter 01

Displays the flame signal in μA .

The BCU measures the flame signal and assesses whether there is a flame on the basis of the switch-off threshold.

4.2.2 Burner switch-off threshold

Parameter 02

Determines the value from which a flame signal is detected.

In the case of UV control, this value can be increased, should the burner to be monitored be influenced by other burners.

If the flame signal is lower than the set switch-off threshold, the BCU will not detect a flame.

The measured flame signal of the system's "own" burner should be at least $3 \mu\text{A}$ (empirical value) higher than the set switch-off threshold.

On the BCU 370..U1 for use with UVD 1, no switch-off threshold will be indicated.

4.2.3 UVS check (1× in 24 hours)

Parameter 17

Activates an automatic restart of the burner control unit after 24 hours combustion time.

Systems in continuous operation can be restarted every 24 hours to check UV sensors that are intended for intermittent operation only.

Parameter 7 = 0: Unlimited burner operation

Parameter 7 = 1: An automatic restart is activated once every 24 hours. The restart begins with pre-purge (parameter 06, "Pre-purge on each start-up" = 1) or starting the burner in the Ignition position (parameter 06, "Pre-purge on each start-up" = 0).

The time starts each time the start-up signal (⌘) is applied. Since the BCU 370 interrupts burner operation autonomously after 24 hours, it is to be verified whether the process allows for the resulting break in heat supply.

4.3 Behaviour during start-up

4.3.1 Minimum burner pause time t_{BP}

Parameter 11

Determines the minimum burner pause time.

To stabilise the burner operation, a minimum burner pause time t_{BP} can be set independently of the central control system.

If the start-up signal (ϑ) drops after fan start or if a safety shut-down occurs, a restart is suppressed for the duration of the minimum burner pause time t_{BP} , which starts to elapse after expiry of the post-purge time t_{PN} (parameter 19).

4.3.2 Burner start-up attempts

Parameter 07

This defines the maximum number of possible start-up attempts of the burner.

For burners which require several start-up attempts due to longer pipes for example, the BCU can automatically carry out several start-up attempts.

Parameter 07 = 1: One start-up attempt

If a safety shut-down takes place during start-up, e.g. on account of a flame signal failure, a fault lock-out occurs once the time t_{SA} has elapsed. The display blinks and shows the cause of the fault.

Parameter 07 = 2 – 4: 2 – 4 start-up attempts

If several start-up attempts are set at the works and if the BCU performs a safety shut-down during start-up, it closes the valves after the safety time t_{SA} has expired and attempts to start up again. Each start-up attempt begins with pre-purge. Once the last programmed start-up attempt has failed, the burner control unit performs a fault lock-out, in case no flame has formed. The display blinks and shows the cause of the fault.

In accordance with EN 746-2 and EN 676 a maximum of four start-ups are permitted in specific cases if the safety of the installation is not impaired. Please note application standards.

NOTE: Only 1 start-up attempt is possible for units with FM or CSA approval.

4.3.3 Switch-on delay time t_E

Parameter 22

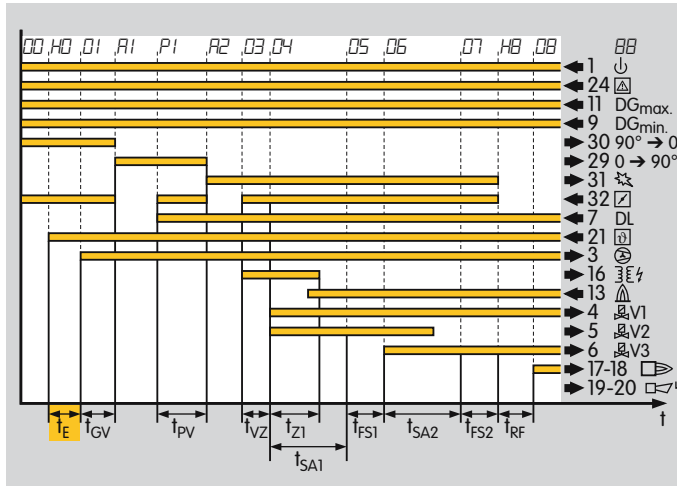

Determines the time between applying the start-up signal (ϑ) and initiating the burner start.

When several burners are activated simultaneously, setting different switch-on delay times t_E prevents the fans from starting at the same time and reduces the load on the power supply.

4.3.4 Pre-ignition time t_{VZ}

Parameter 21

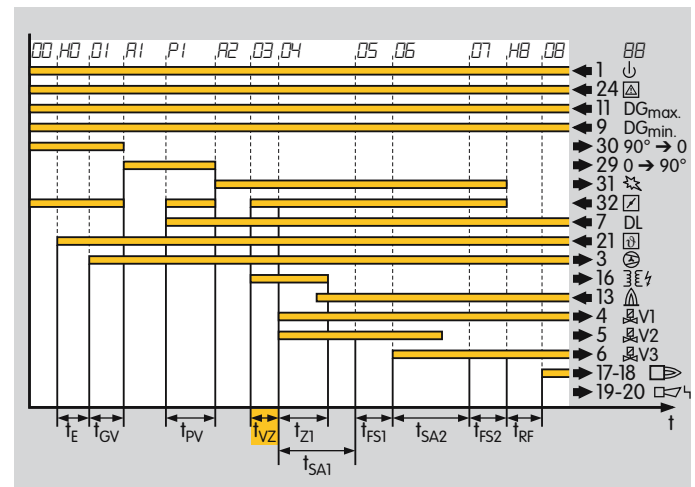

The ignition unit is activated.

The ignition spark can stabilise in the air flow during the pre-ignition time t_{VZ} .

The valves are still closed during the pre-ignition time t_{VZ} . Following pre-ignition t_{VZ} , the safety time t_{SA1} starts to elapse. The valves are opened while the ignition unit continues to operate.

4.3.5 1st safety time on start-up, burner/pilot burner t_{SA1}

Parameter 12

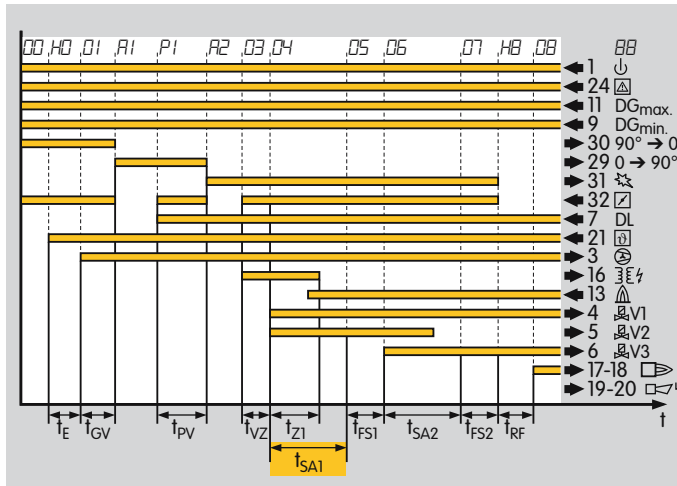

The safety time on start-up t_{SA1} determines when the pilot burner or burner valves will be closed in the event of flame signal failure.

V1 and V2 are opened and the ignition unit is activated as the safety time t_{SA1} starts to elapse. If no flame signal is pending after elapse of the safety time t_{SA1} , the BCU performs a safety shut-down. The valves are closed. The BCU carries out up to 3 further start-up attempts, depending on how parameter 07 “Burner start-up attempts” has been set.

The setting of safety time t_{SA1} is to be determined on the basis of the burner capacity, the type of control and

the relevant application standard, e.g. EN 746-2, EN 676, NFPA 85 or NFPA 86.

4.3.6 1st flame proving period, burner/pilot burner t_{FS1}

Parameter 13

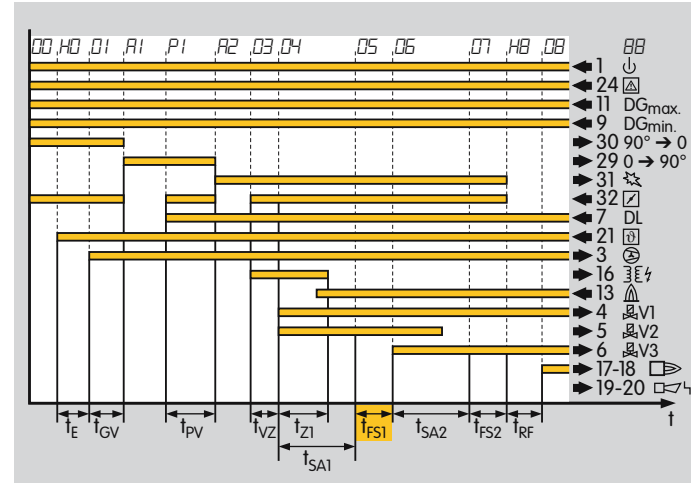

Determines the flame proving period of the burner or pilot burner.

This time elapses before the BCU starts the next program step so as to give the flame time to stabilise.

The flame proving period t_{FS1} starts to elapse once safety time t_{SA1} has expired.

4.3.7 2nd safety time on start-up, main burner t_{SA2}

Parameter 14

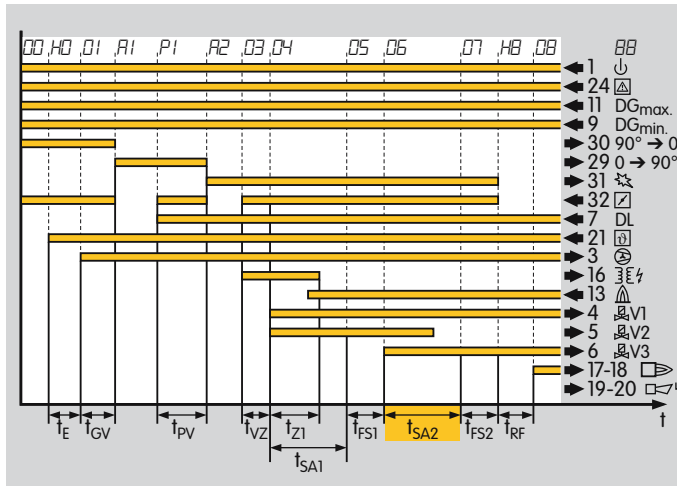

The safety time on start-up t_{SA2} determines when the main burner valves will be closed in the event of flame signal failure.

V3 is opened as the safety time t_{SA2} starts to elapse. One second before the end of the safety time t_{SA2} , V2 is closed (parameter 27 = 0, "Interrupted pilot burner") or remains open (parameter 27 = 1, "Permanent pilot burner"). If no flame signal is pending after elapse of the safety time t_{SA2} , the BCU performs a safety shutdown. Valves V1, V2 and V3 are closed. The BCU carries out up to 3 further start-up attempts, depending on how parameter 07 "Start-up attempts, burner/pilot burner" has been set.

The setting of safety time t_{SA2} is to be determined on the basis of the burner capacity, the type of control and the relevant application standard, e.g. EN 746-2, EN 676, NFPA 85 or NFPA 86.

4.3.8 2nd flame proving period, main burner t_{FS2}

Parameter 15

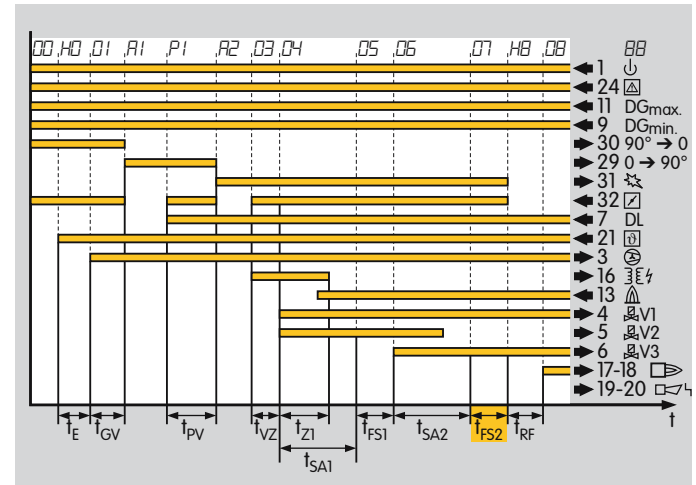

Determines the flame proving period of the main burner in pilot/main burner combinations.

This time elapses before the BCU starts the next program step so as to give the flame time to stabilise.

The flame proving period t_{FS2} starts to elapse once safety time t_{SA2} has expired.

4.4 Behaviour during operation

4.4.1 Minimum combustion time t_B

Parameter 10

Defines the minimum burner combustion time.

To stabilise the burner operation, a minimum combustion time can be set independently of the central control system.

If the start-up signal (ϑ) drops once the first safety time t_{SA1} has started to elapse, the burner remains in operation for at least time t_B . The minimum combustion time t_B starts to elapse following controller enable. If the start-up signal drops before the first safety time t_{SA1} , e.g. during pre-purge, the control unit reverts directly to standby and the burner is not ignited.

4.4.2 Controller enable signal delay time t_{RF}

Parameter 29

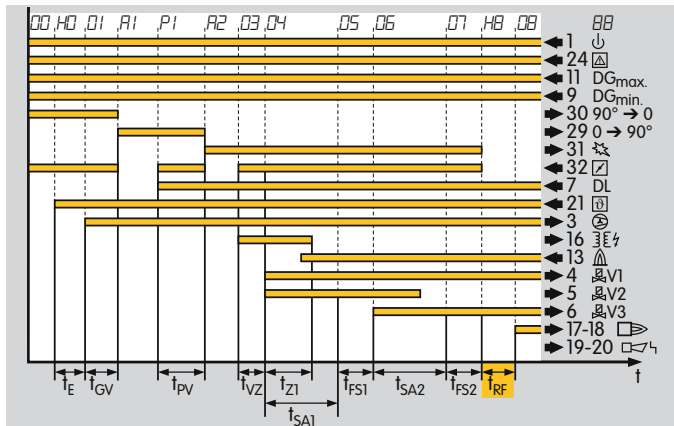

Defines the time between start-up of the burner and controller enable.

The controller enable signal delay time ensures a stable combustion process, e.g. through uniform heating of the entire combustion chamber.

The time t_{RF} starts to elapse

| after expiry of | if |
|-----------------|---|
| t_{SA1} | $t_{FS1} = 0, t_{SA2} = 0$ |
| t_{FS1} | $t_{SA2} = 0$ |
| t_{SA2} | $t_{FS2} = 0$ |
| t_{FS2} | $t_{FS1} > 0, t_{SA2} > 0, t_{FS1} > 0$ |

The BCU shows program status \overline{HB} . After time t_{RF} has elapsed, the BCU closes the operation signalling contact (terminals 17/18) and activates controller enable (terminal 25).

4.4.3 Safety time during operation t_{SB}

Parameter 09

Defines the safety time during operation t_{SB} for valves V1, V2 and V3.

If there is a flame failure while the burner is operating, the BCU closes the valves within the safety time during operation t_{SB} . The default in accordance with EN 298 is 1 s. The safety time during operation t_{SB} can also be set to 2 s. Prolonging the time increases the installation availability in the case of brief-duration fades of the flame signal.

The safety time of the installation during operation (including closing time of the valves) may not exceed in accordance with EN 746-2 3 s, in accordance with NFPA 85 and NFPA 86 4 s. Please note application standards.

4.4.4 Behaviour in the event of flame failure during operation

Parameter 08

Determines whether a restart will be attempted following a safety shut-down during operation.

For burners with occasionally unstable flame signals during operation, a one-off restart can be attempted.

Parameter 08 = 0: Fault lock-out after installation fault.

In the event of an installation fault (e.g. flame failure or air pressure failure), the burner control unit performs a fault lock-out within the safety time during operation

t_{SB} . This involves disconnecting the power from the gas valves. The fault signalling contact closes, the display blinks and shows the current program status (see tables Program status and Fault messages).

Parameter 08 = 1: Restart after installation fault.

If the BCU detects an installation fault (e.g. flame failure) after the second flame proving period has elapsed, the valves are closed and the operation signalling contact is opened within time t_{SB} . The burner control unit now attempts to restart the burner once. The restart begins with pre-purge. For further restart attempts, the burner must have been operational for at least 2 seconds.

If the burner does not function, a fault lock-out occurs. The display blinks and shows the cause of the fault.

In accordance with EN 746-2 and EN 676 a restart may be attempted under certain conditions. The safety of the system must not be impaired. Please note application standards.

4.4.5 Last fault signal

Parameter 03

The BCU shows the last fault message.

In order to analyse a burner system, the last fault message can be called up. In addition, parameters 81 to 90 show the last 10 messages. Extended diagnostics is possible using the BCSoft software.

4.4.6 V2 during burner operation

Parameter 27

Determines whether valve V2 is switched off 1 s before the end of the second safety time t_{SA2} .

On systems with pilot burners, the pilot burner can be switched off once the main burner is operational.

Parameter 27 = 0: Valve V2 is switched off 1 s before the end of the second safety time t_{SA2} . (If t_{SA2} is set to 0, this occurs at the end of the first flame proving period t_{FS1} or at the end of the first safety time t_{SA1} , if $t_{FS1} = 0$).

This setting is required for pilot/main burner systems where the pilot burner does not ignite the main burner safely in each operating status.

Parameter 27 = 1: Valve V2 remains open during the entire burner operation. This setting is valid for directly ignited burners ($t_{SA2} = 0$) and pilot/main burner systems with permanent pilot burner.

4.5 Monitoring/tightness control

4.5.1 Min. gas pressure monitoring

Parameter 23

Determines whether the minimum gas pressure DG_{min} is monitored.

To ensure that there is adequate gas pressure on the burner, the pressure can be monitored using the gas pressure monitor DG_{min} .

Monitoring takes place in the start-up position/standby, during burner start-up or during burner operation. If the signal is not applied, a locking warning signal is triggered and the display shows $\square X$, "Fault DG_{min} in program step X". When the signal is applied again, the BCU 370 attempts to restart the burner, provided the start-up signal (ϑ) is pending.

The requirement for monitoring of the minimum gas pressure is stipulated in the relevant application standard.

4.5.2 Digital input function

Parameter 24

Defines the function of the input on terminal 11.

Parameter 24 = 0: Input has no function.

Parameter 24 = 1: Monitoring of the maximum gas pressure DG_{max} .

To ensure that the permissible gas pressure on the burner is not exceeded, the pressure can be monitored using the gas pressure monitor DG_{max} .

Monitoring takes place in the start-up position/standby, during burner start-up or during burner operation. If the signal is not applied, a fault lock-out occurs and the display shows $\square X$, "Fault DG_{max} in program step X".

Parameter 24 = 3: Monitoring of the pressure switch between V1 and V2/V3 for tightness control (only on BCU..D3). See "Function – Tightness control".

4.5.3 Air monitoring during pre-purge

Parameter 04, activated automatically if parameter 05 “Air monitoring during operation” has also been activated.

This parameter determines whether the air pressure is monitored during pre-purge.

To ensure that there is actually air pressure during pre-purge, the pressure can be monitored using the air monitoring during pre-purge function.

Parameter 04 = 0: No air monitoring during pre-purge. A decrease in the air pressure or a failure in air supply will not be detected.

Parameter 04 = 1: Air monitoring during pre-purge. Air pressure switch signal to terminal DL (7). The BCU checks whether the air monitor signal changes:

- Check of the LOW signal (no air monitoring signal)
Before pre-purge, no signal may be present. A LOW signal must be applied to input DL.
If the LOW signal is not applied, the BCU performs a fault lock-out once the delay time of 25 seconds has elapsed. Fault message: **dl**, “Fault DL static control”.
- Check of the HIGH signal (air monitoring signal activated)
Once the fan has been activated, the BCU checks whether the air monitor switches while the actuator moves to the Open position (start-up with pre-purge) or during the waiting time (quick start). The signal to input DL must be switched to HIGH. If the HIGH sig-

nal is not applied, the BCU performs the set number of further start-up attempts (parameter 07) after a delay time of 25 seconds has elapsed. If no further start-up attempts have been parameterised, a fault lock-out occurs and fault message **dl**, “No air supply during start-up”, is displayed.

Air pressure must be present and a HIGH signal must be applied to input DL during the subsequent pre-purge. If the HIGH signal is not applied, the BCU performs a safety shut-down once the delay time of 25 seconds has elapsed. If no further start-up attempts have been parameterised (parameter 07), a fault lock-out occurs and fault message **dP**, “No air supply during pre-purge”, is displayed.

Depending on the application standard, different air monitoring methods are possible. Along with pressure monitoring, other functions such as fail-safe feedback signals from the actuator or air flow monitoring devices may be required. Please note application standards.

4.5.4 Air monitoring during operation

Parameter O5, if activated, parameter O4 “Air monitoring during pre-purge” is also activated.

This parameter determines whether the air pressure is monitored during burner operation.

To ensure that there is actually air pressure during burner operation, the pressure can be monitored using the air monitoring during operation function.

Parameter O5 = 0: No air monitoring during operation. A decrease in the air pressure or a failure in air supply will not be detected.

Parameter O5 = 1: The air pressure is monitored during operation. During burner start (after pre-purge until the end of the main burner safety time t_{SA2}) and during burner operation (after the end of main burner flame proving period t_{FS2} until the end of normal operation), the air must flow and a HIGH signal must be applied to input DL. If the HIGH signal drops, the BCU performs a safety shut-down.

- DL signal drops during burner start.

If further start-up attempts have been parameterised (parameter O7), a further burner start-up attempt is made. If no further start-up attempts have been parameterised, a fault lock-out occurs and fault message  “No air pressure on DL in program step X”, is displayed.

- DL signal drops during burner operation.

If a restart is parameterised (parameter O8), a one-off burner restart is attempted. If the restart option is not activated, a fault lock-out occurs and fault message  “No air pressure on DL in program step X”, is displayed.

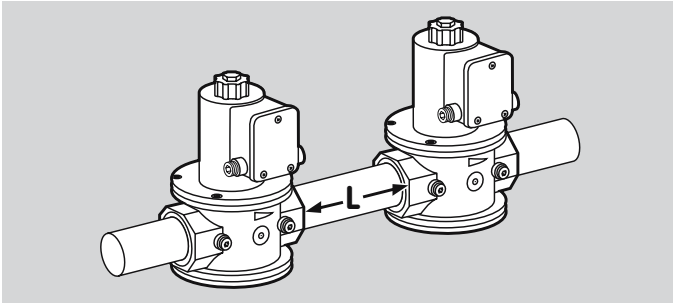

4.5.5 Tightness test period t_p

Parameter 26 on BCU..D3

Defines the tightness test period t_p for the gas solenoid valves.

Depending on burner capacity, the tightness of the gas solenoid valves must be checked in accordance with the relevant application standard, e.g. EN 676, EN 746, NFPA 85 and NFPA 86.

| DN | Basic volume V_G | | Volume per metre V_M | |
|-----|--------------------|--------|------------------------|--------|
| | Litres | Quarts | Litres | Quarts |
| 10 | 0.01 | 0.011 | 0.1 | 0.11 |
| 15 | 0.07 | 0.074 | 0.2 | 0.21 |
| 20 | 0.12 | 0.127 | 0.3 | 0.32 |
| 25 | 0.2 | 0.21 | 0.5 | 0.53 |
| 40 | 0.7 | 0.74 | 1.3 | 1.37 |
| 50 | 1.2 | 1.27 | 2 | 2.11 |
| 65 | 2 | 2.11 | 3.3 | 3.49 |
| 80 | 4 | 4.23 | 5 | 5.28 |
| 100 | 8.3 | 8.77 | 7.9 | 8.35 |
| 125 | 13.6 | 14.37 | 12.3 | 13 |
| 150 | 20 | 21.13 | 17.7 | 18.7 |
| 200 | 42 | 44.38 | 31.4 | 33.18 |

It is possible to check a specific leakage rate \dot{V}_L using the tightness control function. In countries where the Standards and Directives of the European Union are applicable, the maximum leakage rate \dot{V}_L is 0.1% of the maximum flow rate [m³(ft³)/h (n)]. The sensitivity of the tightness control can be adjusted by adapting the test period t_p for each individual application. If a small leakage rate \dot{V}_L is to be detected, a long test period t_p must be set. The test period t_p is the sum of the waiting time t_w , 3 s opening time t_L and measurement time t_M . It is calculated from the inlet pressure p_e [mbar (psig)], the leakage rate \dot{V}_L [l/h (ft³/h)] and the test volume V_P [l (ft³)].

The test volume V_P is determined using the opposite table:

$$V_P = V_G + L \times V_M$$

$$t_p = 4 \times \left(\frac{p_e \text{ [mbar]} \times V_P \text{ [l]}}{\dot{V}_L \text{ [l/h]}} + 1 \text{ s} \right)$$

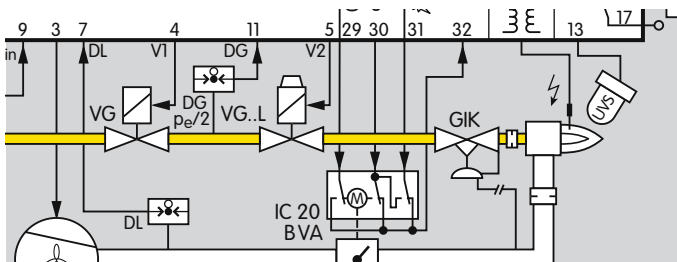

4.5.6 Calculation example

Inlet pressure: $p_e = 50 \text{ mbar (0,725 psig)}$

Flow rate: $\dot{V}_{\max} = 15 \text{ m}^3/\text{h (425,6 ft}^3/\text{h)}$

Leakage rate V_L :

$\dot{V}_L = 15 \text{ m}^3/\text{h (425,6 ft}^3/\text{h)} \times 0.1\% = \mathbf{15 \text{ l/h (0,4256 ft}^3/\text{h)}}$

Test volume V_p :

2 x VG 20, gap: $L = 0.5 \text{ m (19,68 inch)}$

$V_p = 0.12 \text{ l} + 0.5 \text{ m} \times 0.3 \text{ l} = \mathbf{0.27 \text{ l (0,28 qt)}}$

Calculated test period:

$$t_p = 4 \times \left(\frac{50 \times 0.27}{15} + 1 \right) \text{ s} = 7.6 \text{ s}$$

Enter the next highest value using the software: 10 s.

4.6 Air control

4.6.1 Valve control

Parameter 25

Determines whether an actuator connected to terminals 29 to 32 is activated for valve control.

If valve control is deactivated, the BCU 370 can be used to control single-stage-controlled burners.

Parameter 25 = 1: Valve control is active. The BCU activates the outputs on terminals 29, 30 and 31 to move the actuator to the Open (pre-purge), Closed and Ignition positions. When the appropriate position is reached, this information is signalled back by the actuator via the input on terminal 32. The BCU 370 waits for the feedback signal from the actuator once the outputs have been activated. The time required depends on the actuator running time. If the position is not reached within the timeout time of 250 seconds, the BCU displays the fault message "Position not reached".

Parameter 25 = 0: The BCU 370 runs through all program steps without waiting for a feedback signal from the butterfly valve. The outputs for valve control are not activated.

4.6.2 Pre-purge

Parameter 06

This parameter determines whether the BCU pre-purges on the next start-up after a normal shut-down.

Within the scope of the application standard EN 676 pre-purge can be dispensed with under certain conditions. This prevents cold air from entering the combustion chamber and accelerates burner start-up.

Parameter 06 = 1: Pre-purge occurs on each start-up.

Parameter 06 = 0: Pre-purge is omitted if the last shut-down was a normal shut-down and occurred within the last 24 hours. After switching on the BCU, after a safety shut-down or a fault lock-out or after a pause of more than 24 hours, the BCU completes an entire pre-purge cycle.

For burner capacities as from 70 kW, application standard EN 676 requires that a valve check be carried out if pre-purge has been omitted.

For burner capacities as from 117 kW, application standards NFPA 85 and NFPA 86 require a valve check before pre-purge and pre-purge before each system start.

The valves can be checked using a tightness control. See "Function – Tightness control". Please note application standards.

4.6.3 Quick start starts in ...

Parameter 28, active if parameter 06 = 0 ("Quick start") and parameter 25 = 1 ("Valve control").

Determines whether on quick start, the butterfly valve rests in the Ignition position or in the Closed position during standby.

In the Closed position, the amount of combustion air which enters the combustion chamber is minimised.

Parameter 28 = 0: The BCU sets the butterfly valve to the Ignition position for quick start after normal shut-down. Once the start-up signal (ϑ) has been applied, the BCU initiates burner ignition immediately after the fan run up time (parameter 20) and the waiting time.

Parameter 28 = 1: The BCU sets the butterfly valve to the Closed position for quick start after normal shut-down. Once the start-up signal (ϑ) has been applied, the BCU moves the actuator to the Ignition position via the Open position and ignites the burner after the fan run up time (parameter 20) and the waiting time. The time between activating the start-up signal (ϑ) and burner start is determined by the running time of the actuator of the butterfly valve.

4.6.4 Pre-purge time t_{PV}

Parameter 18

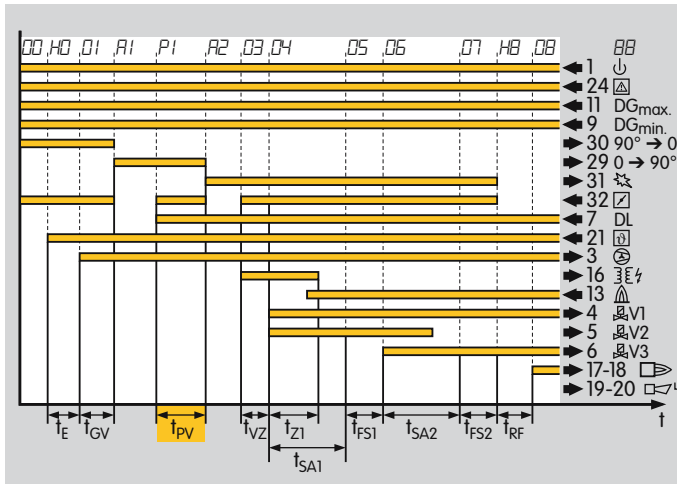

Determines how long the full air flow will be supplied to the combustion chamber before burner start.

Pre-purge removes non-combusted gases from the combustion chamber.

The pre-purge time t_{PV} starts once the actuator has signalled the Open position and the air pressure switch DL contact has closed.

If “Pre-purge on each start-up” is deactivated (parameter 06 = 0), pre-purge is omitted on burner start after a normal shut-down within the last 24 hours.

If the pre-purge time t_{PV} is set to 0 s, pre-purge is always omitted, e.g. even on restart after a safety shut-down. The BCU carries out a quick start on each burner

start. The butterfly valve is moved to the Ignition position via the Open position after normal shut-down.

If tightness control is activated (BCU..D3, parameter 24 = 3), the pre-purge time t_{PV} must be set to at least the value of the test period (parameter 26).

The pre-purge time t_{PV} is to be set on the basis of the relevant application standard (e.g. EN 676, EN 746-2, NFPA 85 or NFPA 86).

4.6.5 Post-purge time t_{PN}

Parameter 19

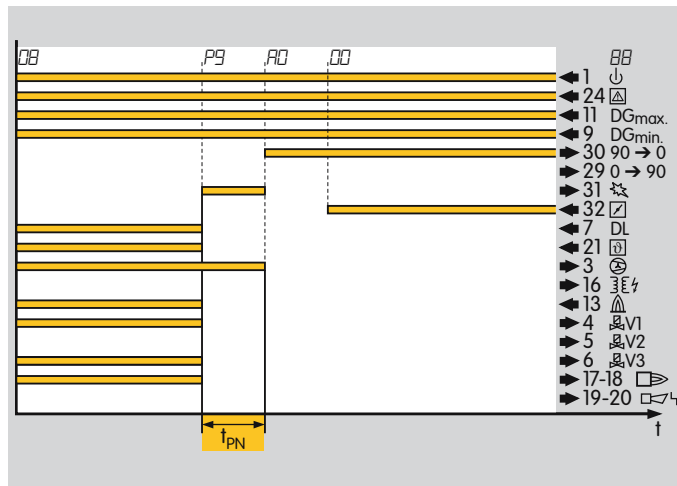

Determines how long air will be supplied to the combustion chamber after burner operation has been terminated.

To remove combustion gas residues from the burner, this can be purged with air after operation.

The post-purge time t_{PN} starts to elapse once the start-up signal (st) has been deactivated or once the first safety time has elapsed in case of a safety shut-down. If the actuator is located above the Ignition position at this time, it moves to the Ignition position. If it is below the Ignition position, the actuator stays in its current position.

Pre-purge on each start-up (parameter 06 = 1):

The actuator moves to the Closed position after the end of the post-purge time t_{PN} .

Quick start (parameter 06 = 0) or pre-purge time = 0 (parameter 18 = 0):

After the post-purge time t_{PN} has elapsed, the actuator moves to the Open position and then to the Ignition position (parameter 28 = 0) or the Low position (parameter 28 = 1).

If tightness control is activated (BCU..D3, parameter 24 = 3) and quick start is activated (parameter 06 = 0), the post-purge time must be set to at least the value of the test period (parameter 26).

4.6.6 Fan run up time t_{GV}

Parameter 20

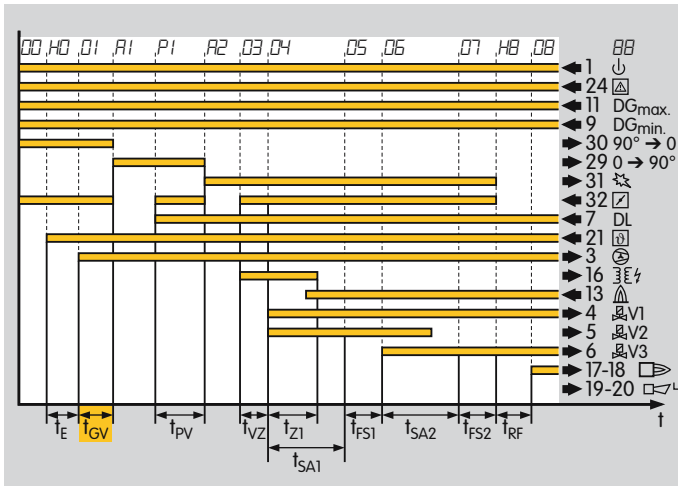

This parameter defines the time between the activation of the fan output (terminal 3) and the opening of the butterfly valve or burner start.

Fan start with the butterfly valve being closed reduces the start-up current of the fan motor.

4.7 Control using PROFIBUS-DP

4.7.1 Bus control activation

Parameter 31 on BCU 370..B1-3

Activates three-point step control via Profibus-DP.

The activation signals for capacity control using the butterfly valve can be transferred via the Profibus-DP.

Once bit 7 of the output byte has been set, the valve moves in the direction of the Closed position. When bit 6 is set, the valve moves to the Open position. If both bits are set, the valve stops. The BCU 370 displays fault message 5E, "Open + Close set simultaneously".

The lower limit of the modulation range is defined using Parameter 32.

4.7.2 Bus control limitation

Parameter 32 on BCU 370..B1-3

Defines the lower limit of the modulation range of the butterfly valve.

Parameter 32 = 0: When bit 7 is activated, the butterfly valve moves to the Closed position. This is defined by the limit switch in the actuator.

Parameter 32 = 2: When bit 7 is activated, the butterfly valve moves to the Ignition position. This is defined by the limit switch in the actuator.

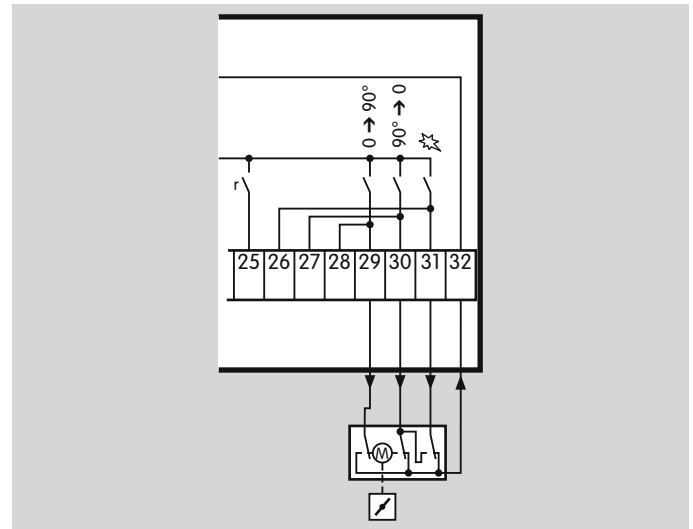

Parameters

Parameter 32 = 1: When bit 7 is activated, the butterfly valve moves to the Low position. For this purpose, terminal 25 is wired to a fourth limit switch in the actuator.

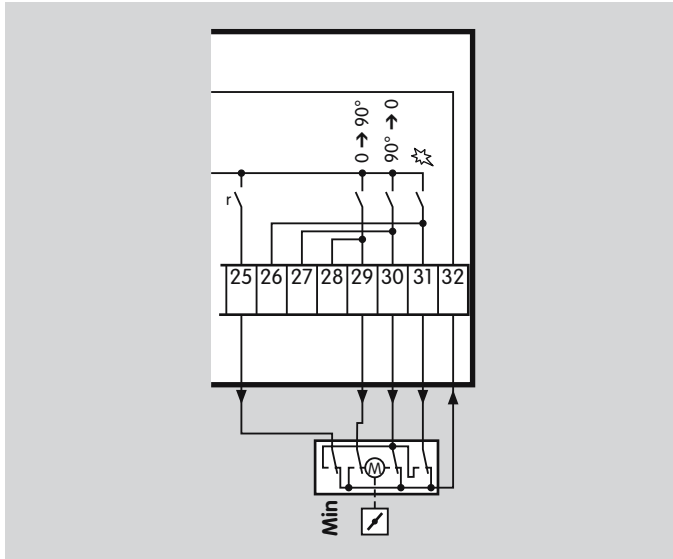

Definition of the modulation range following controller enable

BCU..B1-3 with three-point step control function

| Valve position | Output byte |
|-----------------------------|--|
| Upper end position Open | Bit 6 |
| Lower end position Closed | Bit 7, parameter 32 = 0 |
| Lower end position Low | Bit 7, parameter 32 = 1, terminal 25 wired to separate limit switch |
| Lower end position Ignition | Bit 7, parameter 32 = 2 |



4.8 Manual mode

For convenient setting of the burner or analysing faults.

If the Reset/Information button is pressed for 2 s during switch-on, the BCU reverts to manual mode. Two dots blink on the display.

In this operating mode, the burner control unit operates independently of the status of the inputs Start-up signal (Ø) (terminal 21), Controlled air flow (terminal 22) and Remote reset (terminal 23) as well as the bus inputs on BCU.B1. The functions of the safety interlock (terminal 24) are retained.

Each time after the button is pressed again, the BCU moves to the next section of the program sequence and stops there. After approx. 3 seconds, the flame signal is indicated instead of the operating status. In the event of flame simulation, the flame signal will be displayed immediately.

Following controller enable (status display ) , a connected butterfly valve can be opened and closed as required. By holding the button, the motor is first opened further. The BCU indicates  with blinking dots.

Once the button has been released, the butterfly valve stops in the relevant position. If the button is pressed again, the butterfly valve is closed (Closed position). The BCU indicates  with blinking dots.

A change of direction takes place each time the button is released and pressed again.

When the butterfly valve has reached its final position, the dots disappear.

4.8.1 Operating time in manual mode

Parameter 16

Determines whether the BCU in manual mode is reset to the standby position for manual mode.

Parameter 16 = 0: Manual mode is not limited in time.

If this function has been selected, operation of the burner may be continued manually in the event of failure of the control system or the bus.

Parameter 16 = 1: Five minutes after the last time the button is pressed, the BCU ends burner operation and moves abruptly back to the standby position for manual mode. The burner can be restarted manually.

Manual mode is terminated by switching off the BCU or in the event of a power failure.

4.9 Fault messages

4.9.1 The last 10 fault messages

Parameters 81 – 90

The BCU shows the last 10 fault messages.

In order to analyse a burner system, the last fault messages can be called up in the order in which they occurred. Extended diagnostics is possible using the BCSoft software.

The BCU records the last 10 fault messages internally. Parameter 81 shows the most recent fault message, parameter 82 the one before and so on.

4.10 Password

4.10.1 User-defined password

Parameter 30, 4-digit number

Password saved to protect parameter settings.

To prevent unauthorised changes to parameter settings, a password is stored in parameter 30. Changes to parameter settings can only be made once this number has been entered. The password can be changed using BCSoft. Note the effect of parameter settings on the safe functioning of your system.

The password set at the factory can be found in the delivery note supplied.

5 Selection

BCU 370: For modulating-controlled forced draught burners

| | W | Q | I1 | I2 | I3 | F | E | U0 | U1 | D1 | D3 | B1* | -3* |
|---------|---|---|----|----|----|---|---|----|----|----|----|-----|-----|
| BCU 370 | ● | ● | ● | ○ | ○ | ● | ● | ● | ○ | ● | ○ | ○ | ○ |

● = standard, ○ = available

* If "none", this specification is omitted.

Order example

BCU 370W11FEU0D1

5.1 Type code

| Code | Description |
|------------------|---|
| BCU | Burner control unit |
| W | Mains voltage |
| Q | 230 V AC, 50/60 Hz 120 V AC, 50/60 Hz |
| I1 | Ignition |
| I2* | Electronic ignition, single-pole |
| I3* | Electronic ignition, double-pole |
| no specification | Electronic ignition, double-pole with neutral conductor Without ignition |
| F | Fan control |
| E | Valve control |
| U0 | Flame control |
| U1 | Ionisation control (continuous or intermittent op.) or UV control (intermittent op. with UVS) UV (continuous operation with UVD 1) |
| D1 | DG _{max.} monitoring |
| D3 | Integrated tightness control |
| B1 | For PROFIBUS-DP |
| 3 | Three-point step control via PROFIBUS-DP |

* I2 only for 230 V, I3 only for 120 V

Please quote the required settings of all parameters when ordering, see "Parameters".

6 Project planning information

6.1 Cable selection

Use mains cable suitable for the type of operation and complying with local regulations.

Signal and control line: Max. 1.5 mm².

Control line for UVD 1 wiring: 1 mm².

Cable for burner earth: 4 mm².

Do not route BCU cables in the same cable duct as frequency converter cables or cables emitting strong fields.

6.1.1 Ionisation cable

Use unscreened high-voltage cable for the ionisation cable (see Accessories).

Recommended cable length: Max. 50 m.

Lay cables individually, not in a metal conduit.

Install well away from mains cables and interference from electro-magnetic sources.

Do not lay together with ignition cable.

6.1.2 UV cable

Cable length: Max. 50 m.

Install well away from mains cables and interference from electro-magnetic sources.

Do not lay together with ignition cable.

6.1.3 Ignition cable

(BCU 370..I1, BCU 370..I2 with integrated electronic ignition unit)

Use unscreened high-voltage cable (see Accessories).

Cable length: Max. 1 m.

Avoid external electrical interference.

Connect the ignition cable(s) securely to the integrated ignition unit using the plug connector(s) (see Accessories).

Lay cables individually, not in a metal conduit.

Do not lay UV/ionisation cable and ignition cable(s) together and lay them as far apart as possible.

Feed out of the BCU on the shortest possible route (no loops). Push through corresponding knock-out hole(s) in the housing and use enclosed M16 cable gland(s).

Only use radio interference suppressed electrode adapters (with 1 k Ω resistor), see "Accessories".

For units with external ignition, e.g. ignition transformer TGI, please note the corresponding unit instructions.

6.2 Fan control

The BCU features an output for fan control. The max. start-up current of the fan motor may not exceed the permitted contact rating (see Technical data) of this output. If necessary, an external contactor must be used.

6.3 Controlling the butterfly valve



The required burner commissioning time depends on the running time of the butterfly valve actuator.

The BCU 370 waits for the feedback signal to indicate that the actuator has reached the Open position, for instance, before the pre-purge time is started.

The Ignition position is always approached via the Open position.

Once the butterfly valve has been set to the relevant position, a plausibility check takes place. The related control output is switched off briefly. The feedback signal must drop accordingly.

6.4 Safety interlock (Limits)

The limiters in the safety interlock (linking of all the relevant safety control and switching equipment for the use of the application, for example STB [safety temperature limiter]) must isolate terminal 24 from the voltage supply. If the safety interlock is interrupted, the display shows a blinking  as a warning signal. The program sequence is interrupted. All of the BCU 370's outputs are disconnected from the electrical power supply. The burner control unit restarts when the safety interlock is switched on again and the start-up signal () activated.

6.5 Too many remote resets

If a remote reset is made 5 times in 15 minutes (terminal 23 or by bus signal), the BCU is locked, shows fault message , "Too many remote resets", and can only be reset by pressing the Reset/Information button.

6.6 Protecting the ignition unit from overload

The BCU protects the integrated ignition unit and the electronic switch from overload. Excessive switching triggers a warning signal (blinking ). After the minimum cycle time has elapsed, the BCU starts.

The minimum cycle time saved in the BCU can be calculated using the formula:

$$\text{Minimum cycle time} = (t_{VZ} + t_{SA1} - 1) \times 6$$

Example:

$$\text{Pre-ignition time } t_{VZ} = 2 \text{ s,}$$

$$\text{1st safety time on start-up } t_{SA1} = 3 \text{ s}$$

$$(2 \text{ s} + 3 \text{ s} - 1) \times 6 = 24 \text{ s}$$

In this example, the BCU 370 may not be started more often than every 24 s.

If an external ignition unit/transformer is being used, the formula is as follows:

$$\text{Minimum cycle time} = (t_{VZ} + t_{SA1} - 1) \times 2$$

Adjust the minimum burner pause time t_{PB} (parameter 11) correspondingly, if required.

6.7 Wiring

The BCU is suitable for hard wiring only. Do not reverse phase and neutral conductor. Different phases of a three-phase current system must not be installed at the inputs. Do not connect voltage to the outputs.

On BCU 370..B1 for PROFIBUS-DP, no voltage may be connected to terminals 17 – 23. Otherwise, the BCU may be damaged.

6.7.1 Single-electrode operation with external ignition unit

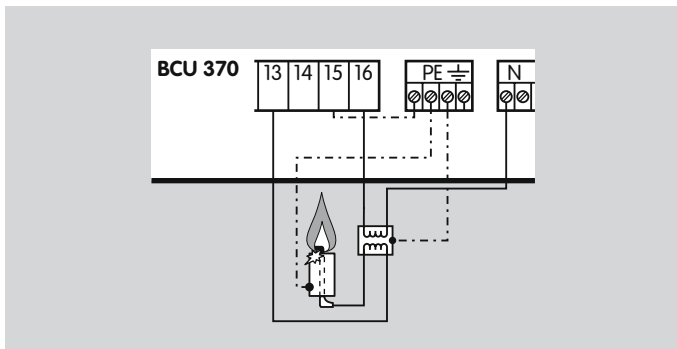

If a burner only has one electrode, which is used for ignition and ionisation control, an external ignition transformer must be used, e.g. TZI or TGI.

6.8 BCU switched off

The BCU indicates . In general, it cannot be activated when no mains voltage is applied or the burner control unit is switched off. The fault signalling contact is

only closed when the BCU is supplied with voltage and switched on.

6.9 Note on EC or CSA and FM type-examination

Since EN 298 (1993) or NFPA 85 and NFPA 86 does not describe all functions of the BCU 370, the operator is responsible for ensuring that all parameters and functions are matched to the respective application.

6.10 Contact protection devices

The safety-related switch contacts on the BCU 370, e.g. for actuation of the gas solenoid valves, are protected by an internal fuse. This fuse cannot be replaced, since safe opening of the contacts is not guaranteed following overload or a short-circuit, e.g. due to a wiring fault. The BCU must be returned to the manufacturer for repair.

6.11 Installation

Recommended installation position: vertical (cable glands pointing downwards).

Detach the upper section of the BCU, remove and screw on lower section with four screws \varnothing 4 mm. Replace upper section and screw into place.

6.12 Protective circuits

Connected control elements must be equipped with protective circuits in accordance with the manufacturer's instructions. This prevents high voltage peaks which can cause malfunction of the BCU.

7 Flame control ...

7.1 ... with ionisation sensor

The BCU generates an alternating voltage (230 V AC) between the sensing electrode and burner earth. The flame rectifies this voltage. Only the DC signal ($>1 \mu\text{A}$) is detected by the burner control unit.

A flame cannot be simulated.

Ignition and monitoring with a single electrode are possible if an external ignition transformer is used.

7.2 ... with UV sensor

A UV tube inside the UV sensor detects the ultraviolet light of a flame. It does not respond to sunlight, incandescent bulb light or infrared radiation emitted by hot workpieces or red-hot furnace walls.

In the event of incident UV radiation the UV sensor rectifies the supplied alternating voltage. As with ionisation control, the burner control unit only detects this DC signal.

When using UV sensors of Type UVS, the burner control unit may be used for intermittent operation only. This means that operation must be interrupted at least once every 24 hours. This can be programmed using parameter 17.

For further information, see brochure UVS.

The burner control unit BCU..U1 is prepared for UV sensor UVD 1. This enables continuous operation.

See Connection diagrams BCU 370/BCU 370..U1.

8 Accessories

8.1 High-voltage cable

FZLSi 1/7 up to 180 °C (356 °F), Order No.: 04250410,
FZLK 1/7 up to 80 °C (176 °F), Order No.: 04250409.

8.2 BCSoft



Opto-adapter including BCSoft CD-ROM
Order No.: 74960437

The current software can be downloaded from our Internet site at
www.docuthek.com.

Log on to the Docuthek and then choose document type “Software”.

8.3 Radio interference suppressed electrode adapters

Plug cap, 4 mm, interference-suppressed,
Order No.: 04115308.

Straight adapter, 4 mm, interference-suppressed,
Order No.: 04115307.

Straight adapter, 6 mm, interference-suppressed,
Order No.: 04115306.

8.4 Connection kit BCU 370

2 M16 cables glands,
2 plug connectors for ignition cable,
2 seal inserts for M20 cable glands.

The connection kit is included in the scope of delivery for the lower section.
Order No.: 74960479

8.5 Set of stickers BCU 370

Various stickers with information in the following languages: D, F, I, NL and E,
sticker: “Important, changed parameters”.

The set of stickers is included in the scope of delivery for the upper section.
Order No.: 74960480

8.6 Device master data file for BCU 370..B1

The DMD file can be downloaded from our Internet site at
www.docuthek.com.

Log on to the Docuthek and then choose document type “Software”.

Device master data file on diskette
Order No.: 74960460

9 Technical data

Mains voltage:

BCU..W: 230 V AC, -15/+10%, 50/60 Hz, or

BCU..Q: 120 V AC, -15/+10%, 50/60 Hz,

for grounded or ungrounded mains.

Flame control with UV sensor or ionisation sensor.

Flame signal for:

Ionisation control: 1 – 28 μ A,

UV control: 1 – 35 μ A.

For intermittent or continuous operation.

Air pressure check during pre-purge and operation by external air pressure switch DL.

Maximum length of ignition cable with integrated electronic ignition: 1 m.

Maximum length of ionisation/UV cable: 50 m (164 ft).

Max. number of operating cycles: 250,000.

Ambient temperature:

BCU 370: -20 – +60 °C (-4 – +140 °F),

BCU 370..I: -10 – +60 °C (14 – +140 °F),

no condensation permitted.

Enclosure: IP 54 pursuant to IEC 529.

Housing made of impact-resistant and heat-resistant plastic. Plug-in upper section with operating and display elements.

Lower section with connection terminals, earthing strip and pre-wired neutral bus with spacious wiring chamber.

1x M25 multiple screw connector, 4x 7 mm cable grommets,

2x M20 multiple screw connectors, 2x 7 mm cable grommets, and loosely enclosed

1x or 2x M16 plastic screw connector(s) for the ignition cable(s).

Voltage to inputs, valves, fan, controller enable, actuator and ignition unit = mains voltage.

Power consumption: Approx. 9 VA plus approx. 50 VA for integrated ignition.

Input voltage signal inputs:

| Rated value | 120 V AC | 230 V AC |
|-------------|--------------|-------------|
| Signal "1" | 80 – 126.5 V | 160 – 253 V |
| Signal "0" | 0 – 20 V | 0 – 40 V |

Input current signal "1": Typ. 2 mA

Output to ignition transformer:

No-switch contacts via semi-conductor.



Technical data

Contact rating:

Valves: Max. 1 A, $\cos \varphi = 1$,

Butterfly valves: Max. 1 A, $\cos \varphi = 1$,

Ignition: Max. 1 A, $\cos \varphi = 0.3$,

Controller enable signal: Max. 1 A, $\cos \varphi = 1$,

the contacts may be loaded with a max. total of 2.5 A,

Fan: Max. 3 A, start-up current: Max. 6.5 A < 1 s.

The outputs may be loaded with a max. total of 4 A.

Operation and fault signalling contacts:

Dry Contact, max. 1 A, 253 V, not fused internally.

Reset/Information button: Max. number of operating cycles: 1000.

Fuse in BCU, replaceable, F1: T 5A H, pursuant to IEC 60127-2/5.

Permissible UV sensors:

Elster Kromschröder models UVS 1, 5, 6, 8 and UVD 1.

Weight: Approx. 1.8 kg.

9.1 PROFIBUS-DP

Manufacturer ID: 0x08EC.

ASIC type: SPC3.

SYNC- and FREEZE-capable.

Baud rate detection: Automatic.

Min. cycle time: 0.1 ms.

Diagnostic bytes: 6 (DP Standard).

Parameter bytes: 7 (DP Standard).

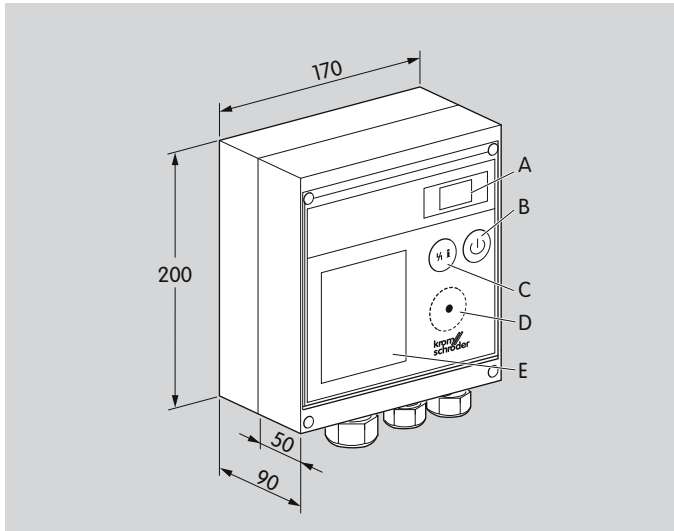





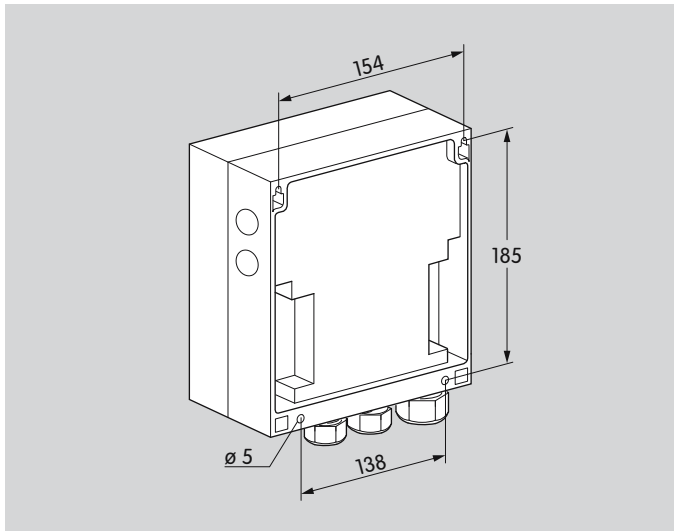













9.2 Operating controls and dimensions

- A: 2-digit 7-segment display
 - B: Off switch, deactivates the BCU, outputs are disconnected from the electrical power supply
 - C: Reset/Information button to reset the system after a fault, to scan parameters on the display or to control manual operation
 - D: Optical interface
 - E: BCU label with the most important status messages in English
- Additional stickers in D, F, I, NL and E enclosed

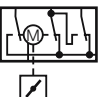

10 Legend

| | |
|---|---|
|  | Display |
|  | Blinking display |
|  | Ready |
|  | Safety interlock (Limits) |
|  | Start-up signal |
|  | Controlled air flow |
|  | Ignition transformer |
|  | Gas valve |
|  | Flame signal |
|  | Operating signal |
|  | Fault signal |
|  | Reset |
|  | Input signal |
|  | Output signal |
|  | Flame simulation check |
|  | Pressure switch (DL for air, DG for gas) |
|  | Ignition/Ignition position |
|  | Three-point step controller |
|  | Actuator (in connection diagram) |

11 Glossary

11.1 Safety shut-down

After an installation fault (e.g. flame or air pressure failure), the burner control unit performs a safety shut-down. This involves disconnecting the power from the gas valves and the ignition transformer. The operation signalling contact and the controller enable signal are deactivated.

After a safety shut-down, the burner control unit can either restart or perform a fault lock-out, depending on the parameter settings.

11.2 Fault lock-out

In the event of a fault lock-out, the fault signalling contact closes, the display blinks and shows the current program status (see table Fault messages). Gas valves and ignition transformer are disconnected from the electrical power supply.

After a fault lock-out, the burner control unit can be reset manually with the button on the front panel or using an external button. Several BCUs can be reset at the same time via an external button.

The BCU cannot be reset by mains failure (fault lock-out which cannot be changed). The fault signalling contact does, however, open as soon as the mains voltage fails.

11.3 Warning signal

The BCU 370 reacts to operating faults, e.g. in the case of permanent remote resets, with a warning signal. The display blinks and shows the corresponding warning message. The warning signal ends once the cause has been eliminated.

The program sequence continues. No fault signal is activated (terminals 19/20).

11.4 Timeout 25 s/250 s

For some process faults, a timeout phase elapses before the BCU 370 reacts to the fault. The phase begins as soon as the BCU 370 detects a process fault and ends after 25 s or 250 s. A safety shut-down or a fault lock-out then occurs. If the process fault ends during the timeout phase, the process continues as before.

12 Annex

12.1 Status and fault messages for PROFIBUS-DP

This table can be used to program the master.

| Input bytes (BCU → master) | | |
|----------------------------|---|--|
| Byte 2 | Byte 0, Bit 2 = 0 (Status message) | Byte 0, Bit 2 = 1 (Fault message) |
| 0 | 0 Start-up position/standby | |
| 1 | A0 Valve moves to Closed position | 01 Flame simulation |
| 2 | 01 Fan run up time | |
| 3 | A1 Butterfly valve moves to Open position | |
| 4 | P1 Pre-purge time | 04 Start-up without flame signal |
| 5 | A2 Butterfly valve moves to Ignition position | 05 Flame failure during 1 st flame proving period |
| 6 | 03 Pre-ignition time | 06 Flame failure during 2 nd safety time |
| 7 | 04 1 st safety time on start-up | 07 Flame failure during 2 nd flame proving period |
| 8 | 05 1 st flame proving period | 08 Flame failure during operation |
| 9 | 06 2 nd safety time on start-up | |
| 10 | 07 2 nd flame proving period | d0 Fault Air monitor break contact check |
| 11 | 08 Controller enable signal | d1 Fault Air monitor make contact check |
| 12 | P9 Post-purge time | d2 Fault Air supply while butterfly valve moves to Ignition position |
| 13 | | d3 Fault Air supply during pre-ignition time |
| 14 | | d4 Fault Air supply during 1 st safety time on start-up |
| 15 | | d5 Fault Air supply during 1 st flame proving period |
| 16 | | d6 Fault Air supply during 2 nd safety time on start-up |
| 17 | | d7 Fault Air supply during 2 nd flame proving period |
| 18 | | d8 Fault Air supply during operation |
| 19 | | dP Fault Air supply during pre-purge time |



| Input bytes (BCU → master) | | |
|----------------------------|---|--|
| Byte 2 | Byte 0, Bit 2 = 0 (Status message) | Byte 0, Bit 2 = 1 (Fault message) |
| 20 | u0 Fault DG _{min} during standby | |
| 21 | u1 Fault DG _{min} while butterfly valve moves to Open position | |
| 22 | u2 Fault DG _{min} while butterfly valve moves to Closed position | |
| 23 | u3 Fault DG _{min} during pre-ignition time | |
| 24 | u4 Fault DG _{min} during 1 st safety time on start-up | |
| 25 | u5 Fault DG _{min} during 1 st flame proving period | |
| 26 | u6 Fault DG _{min} during 2 nd safety time | |
| 27 | u7 Fault DG _{min} during 2 nd flame proving period | |
| 28 | u8 Fault DG _{min} during operation | |
| 29 | u9 Fault DG _{min} during post-purge time | |
| 30 | | o0 Fault DG _{max} in start-up position/standby |
| 31 | | o1 Fault DG _{max} while butterfly valve moves to Open position |
| 32 | | o2 Fault DG _{max} while butterfly valve moves to Closed position |
| 33 | | o3 Fault DG _{max} during pre-ignition time |
| 34 | | o4 Fault DG _{max} during 1 st safety time during operation |
| 35 | | o5 Fault DG _{max} during 1 st flame proving period |
| 36 | | o6 Fault DG _{max} during 2 nd safety time during operation |
| 37 | | o7 Fault DG _{max} during 2 nd flame proving period |
| 38 | | o8 Fault DG _{max} during operation |



| Input bytes (BCU → master) | | |
|----------------------------|--|---|
| Byte 2 | Byte 0, Bit 2 = 0 (Status message) | Byte 0, Bit 2 = 1 (Fault message) |
| 39 | | o9 Fault DG _{max} during post-purge time |
| 40 | | A0 Butterfly valve closed position not reached |
| 41 | | A1 Butterfly valve open position not reached |
| 42 | | A2 Butterfly valve ignition position not reached |
| 50 | | 10 Too many remote resets |
| 58 | | bE Bus module error |
| 61 | | 31 CRC error parameter |
| 62 | 32 Undervoltage | |
| 63 | | 33 EEPROM parameter exceeds limit value |
| 65 | | 35 Fault Valve feedback |
| 66 | | 36 Tightness control: V1 leaking |
| 67 | | 37 Tightness control: V2/V3 leaking |
| 80 | 50 Safety interlock failure | |
| 82 | 52 Permanent remote reset | |
| 83 | 53 Timing cycle too short | |
| 85 | 55 DG _{min} oscillating | |
| 86 | 56 Open + Close set simultaneously | |
| 99 | 99 Internal error | |
| 100 | H0 Switch-on delay time/pause time | |
| 104 | C1 Controlled air flow | |
| 108 | H8 Controller enable signal delay time | |

Feedback

Finally, we are offering you the opportunity to assess this “Technical Information (TI)” and to give us your opinion, so that we can improve our documents further and suit them to your needs.

Clarity

Found information quickly
Searched for a long time
Didn't find information
What is missing?
No answer

Comprehension

Coherent
Too complicated
No answer

Scope

Too little
Sufficient
Too wide
No answer



Use

To get to know the product
To choose a product
Planning
To look for information

Navigation

I can find my way around
I got “lost”
No answer

My scope of functions

Technical department
Sales
No answer

Remarks

Contact

Elster GmbH
Postfach 2809 · 49018 Osnabrück
Strothweg 1 · 49504 Lotte (Büren)
Germany

Tel +49 541 1214-0
Fax +49 541 1214-370
info@kromschroeder.com
www.kromschroeder.com

The current addresses of our international agents are available on the Internet:
www.kromschroeder.de/Weltweit.20.0.html?&L=1

We reserve the right to make technical modifications in the interests of progress.
Copyright © 2016 Elster GmbH
All rights reserved.

